

CAMERON® Fully Welded Ball Valves

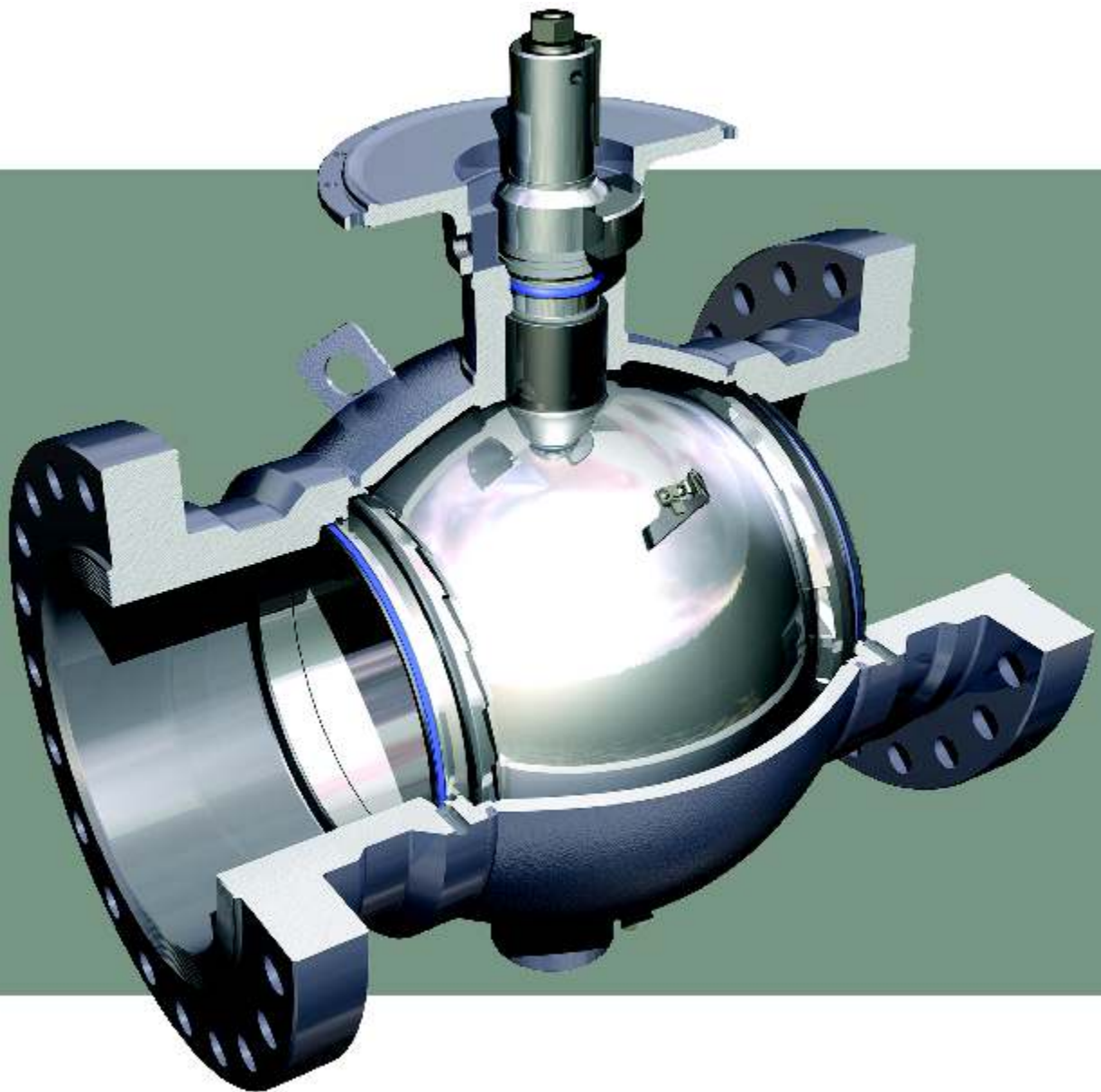

For Benelux:



WEGMAN

Utrecht, The Netherlands
T: +31 (0)30 263 4000
F: +31 (0)30 263 4005
wegman@wegman.nl

CAMERON®

TABLE OF CONTENTS

CAMERON FULLY WELDED BALL VALVES

Features and Benefits 2

In-line Sphere Launcher 6

Accessories 7

HOW TO ORDER

Standards, Specifications and Materials 8

DIMENSION TABLES

ASME/ANSI Class 150 through 2500
(PN 20 through PN 420)
Full and Reduced Port Valves 10

API PRESSURE CLASS 2000, 3000 & 5000 psi

Full and Reduced Port Valves 23

DIMENSION TABLES

Actuator Mounting Information 26

TRADEMARK INFORMATION 29

FULLY WELDED BALL VALVES - FEATURES AND BENEFITS

One of the most trusted valves in the petroleum industry, it combines the strength of forged components with a lightweight and compact spherical design.

CAMERON Fully Welded Ball Valves satisfy ASME/ANSI 150 through 2500 (PN 20 through PN 420) and API 2000 through 10,000 standards. Made of forged steel to assure uniform fine grain structure and toughness, they may be specified in sizes from 2 in. to 56 in. (50 mm to 1400 mm).

Engineered for heavy duty, maintenance free performance, the CAMERON Fully Welded Ball Valve is commonly selected for a number of applications, including:

- Gas transmission
- Products pipeline
- Measurements skids
- Dehydration systems
- Gas separation systems
- Natural gas storage
- Dryer service
- NGL plants
- NGL pipeline
- Compressor stations
- CO₂ services
- Offshore
- Subsea

The distinctive design of the CAMERON Fully Welded Ball Valve gives it maximum strength at minimum weight as well as maximum resistance both to pipeline pressures and stresses. The compact, spherical design also eliminates body flanges, thus reducing overall size and potential leak paths.

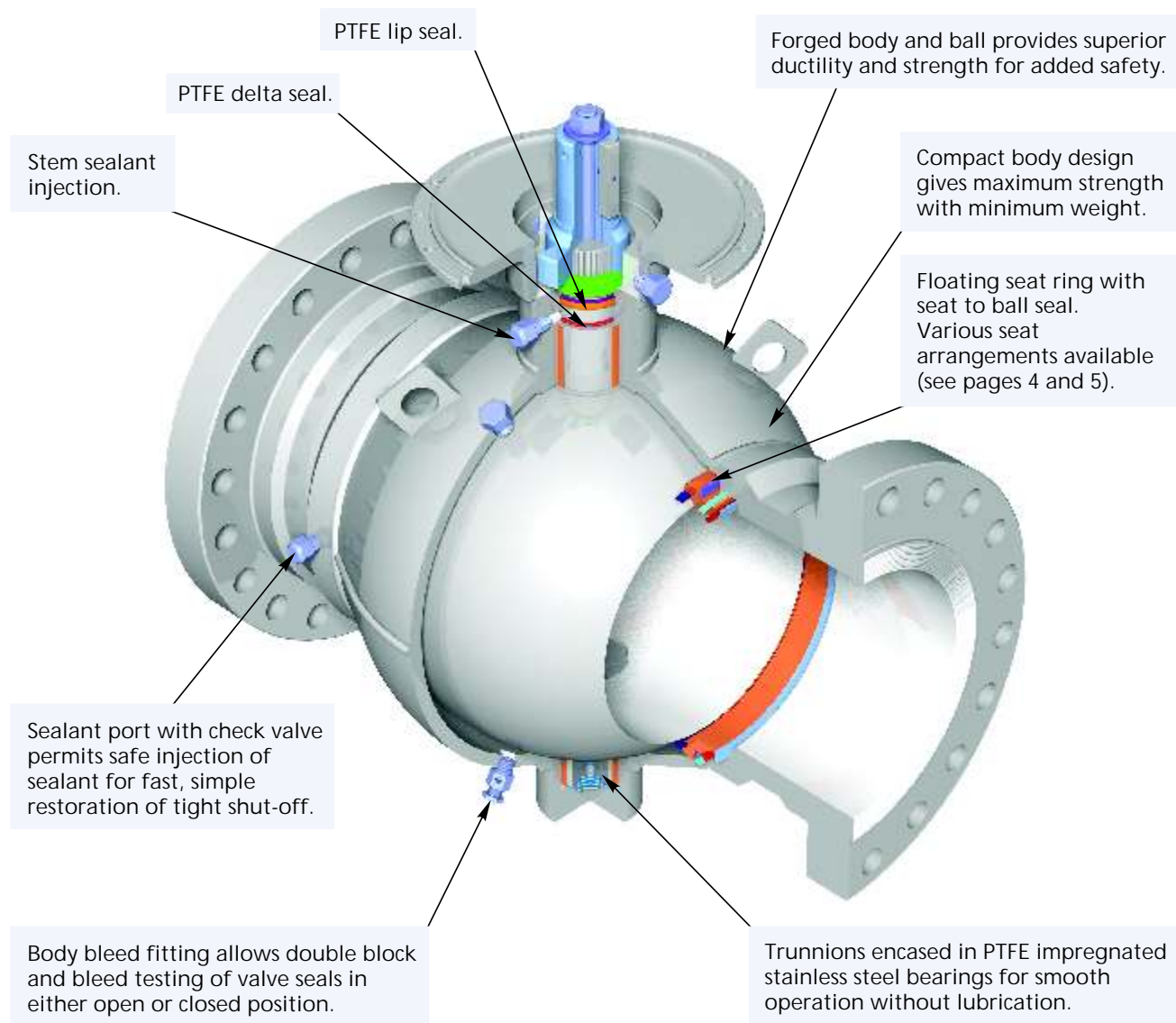

FULLY WELDED BALL VALVES FEATURES AND BENEFITS

REPLACE STEM SEAL

In the unlikely event of a stem seal needing replacement, it can be accomplished safely with the valve in service.

With the body cavity vented all line pressure to the stem area is also vented. (Please contact your Cameron's Valves & Measurement group representative to obtain maintenance procedures.)

SAFEGUARD DOWNSTREAM WORK

With the valve closed and the vent fitting open, the possibility of the line media reaching a work area is removed.

FIRE TESTED FOR SAFETY

CAMERON Fully Welded Ball Valves can be supplied to API 6FA, API 607 and ISO 10497 standards.

Fire test programs are ongoing. If industry standards change or customer requirements vary from above, call your Cameron's Valves & Measurement group representative.

STANDARDS AND SPECIFICATIONS

(See page 8 for specification details)

SIZES

- 2 in. through 56 in.
(50 mm through 1400 mm)
Full, Reduced and Venturi Bore

PRESSURE CLASSES

- ASME/ANSI Class 150 through 2500
(PN 20 through PN 420)
API 2000 through 10,000 psi

OPERATING TEMPERATURES

- From -50°F to 375°F (-46°C to 190°C)

END CONNECTIONS

- Flanged, Weld and Weld by Flange, etc.

BODY STYLES

- Fully Welded

STANDARD MATERIAL

- Forged Carbon Steel

OPTIONAL MATERIALS

- Seat/Seal Trim options include: regular, corrosion resistant and Sour (NACE MR0175)

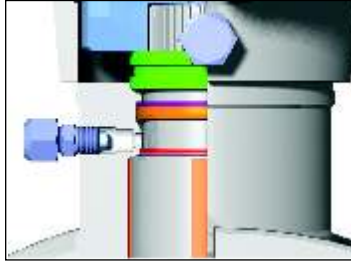

STEM SEALS

Delta seals and lip seals made of PTFE are incorporated in the upper stem area. PTFE is a low friction, non-deteriorating material that is not subject to rapid decompression explosion. Most valve sizes have a provision for the injection of sealant to establish a secondary seal.

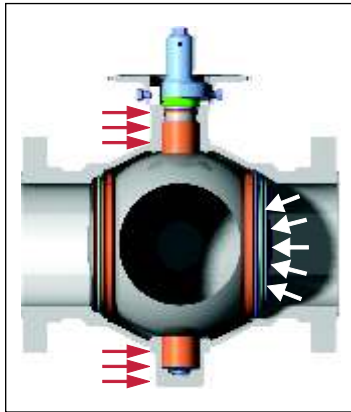

TRUNNION SUPPORTED BALL ALLOWS LOW TORQUE OPERATION

Regardless of size or pressure rating, every CAMERON ball valve is trunnion mounted. High strength forged stems are located in PTFE impregnated stainless steels bearings for smooth, accurate operations. Trunnion mounted stems absorb the thrust from line pressure, preventing excess friction between the ball and seats, so even at full rated working pressure, operating torque stays low.

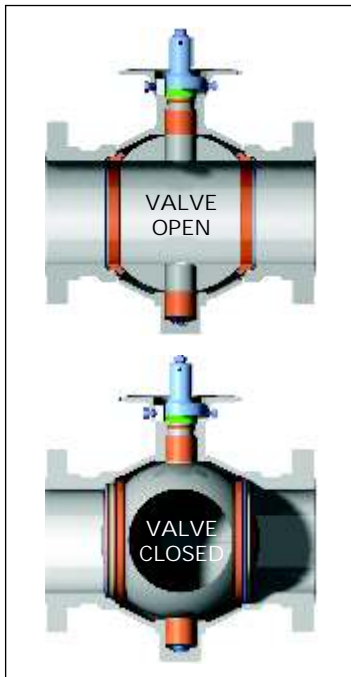

DOUBLE BLOCK AND BLEED

Whether in the fully open or fully closed position, pressure on each side of the ball is blocked from the body cavity by the seat ring. The body cavity can then be bled down or drained through the body port.

When you block and bleed a CAMERON Ball Valve the following can be accomplished:

TEST VALVE INTEGRITY

When CAMERON Ball Valve body is vented this verifies the seat seals integrity. This test can be performed with the valve open or closed prior to facility maintenance. By verifying valve integrity unforeseen valve leakage can be prevented.

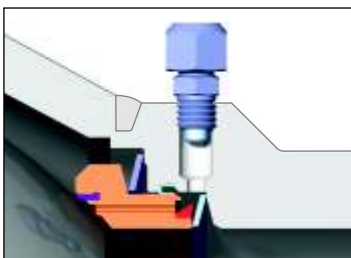

SECONDARY SEAT SEAL

The sealant injection system provides a fast, simple way of restoring tight shut off if any foreign object should damage the sealing surfaces.

The injection system can also be used for routine flushing of the seat ring area in services where this may be required.

FULLY WELDED BALL VALVES STANDARD SEAT DESIGN

In service since the early '60s, the standard seat arrangement has proven itself to be of sound design.

This arrangement is available in all CAMERON Fully Welded Ball Valves and includes all features and benefits indicated on the preceding pages.

FEATURES AND BENEFITS

UPSTREAM SEALING

At low pressure, seat to ball contact is maintained by Belleville springs.

At higher pressures, seat contact is reinforced by line pressure.

AUTOMATIC INTERNAL RELIEF OF BODY PRESSURE

Relief of excess body cavity pressure is automatic, avoiding dangerous pressure build up. Any pressure exceeding downstream line pressure by approximately 200 psi pushes the downstream seat away from the ball, allowing the pressure to relieve into the pipeline.

ROTATING SEAT RINGS

A standard in the CAMERON Fully Welded Ball Valve sizes 14 in. (350 mm) and larger, the CAMERON Fully Welded Ball Valve incorporates the exclusive rotating seat feature. Both seats rotate 15 degrees each time the valve is closed, exposing a new pinch point, evenly distributing seat wear.

DISTRIBUTE SEAT WEAR

The pinch point is the area of the seat insert that experiences an increased velocity when the valve is seated close and unseated open. This is where the seat seal experiences the most wear, and in most valves where a leak path begins. By rotating the seat ring, the pinch point wear is distributed throughout the seat seal providing a substantial increase of seat life.

PREVENTS BUILD UP

In some services a valve can experience harmful sediment build up around the seat ring. This can cause the seat to stick and not seal properly.

The CAMERON Fully Welded Ball Valve with exclusive rotating seat can handle these harsher services. As the seat rotates it will break up or prevent any build up.

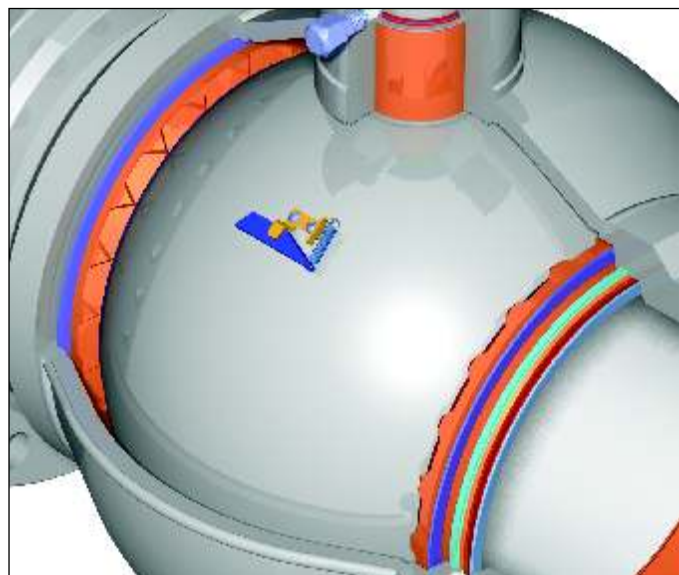
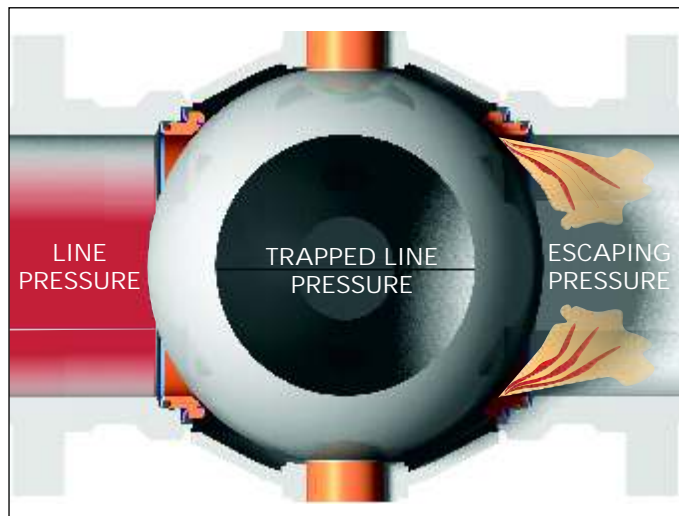
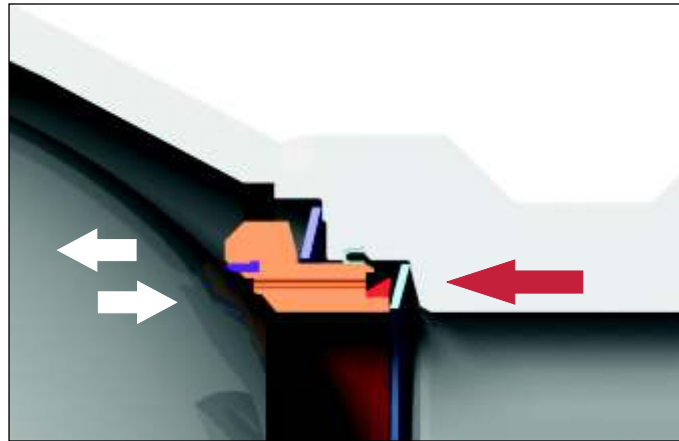

FULLY WELDED BALL VALVES ALTERNATE SEAT DESIGN

The CAMERON Fully Welded Ball Valve is available with double acting and metal to metal seats to accommodate a variety of applications and customer preferences.

DOUBLE ACTING

CONVENTIONAL UPSTREAM SEALING

With the upstream pressure, the bi-directional body to seat seal is pushed toward the front sealing face of its retaining pocket. This creates an unbalanced pressure annulus between the body seal and the inside diameter of the seat insert, forcing the seat insert against the ball.

DOWNSTREAM SEALING

With the downstream pressure, the bi-directional body to seat seal is pushed toward the back sealing face of its retaining pocket. This creates an unbalanced pressure annulus between the outside diameter of the seat insert and the body seal diameter, also forcing the seat insert against the ball.

METAL-TO-METAL

For severe service applications where a soft seat insert would be unsuitable, a metal-to-metal design can be provided. In this design both the seat and the ball are coated with Tungsten Carbide which is resistant to corrosion and wear making it suitable for abrasive services. This type of seat is upstream sealing and incorporates internal relief of body pressure.

ELASTOMER SEAL

A small elastomer seal held by the seat ring performs two services. It wipes the surface of the ball to prevent surface damage while providing a bubble tight seal at low pressures.

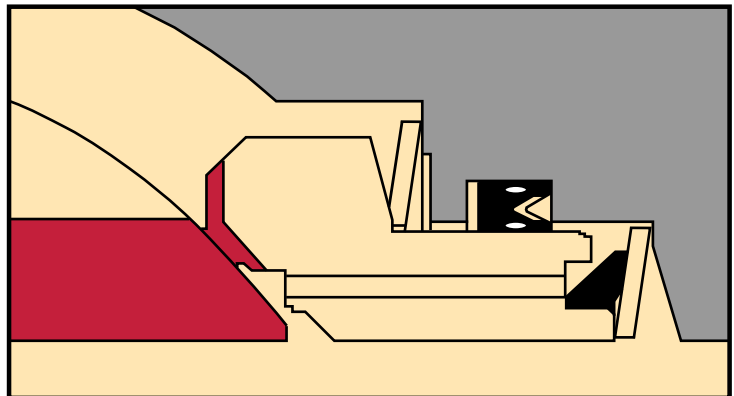
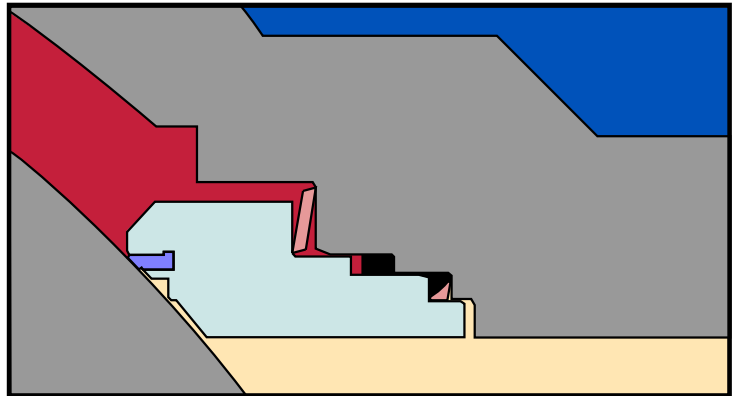
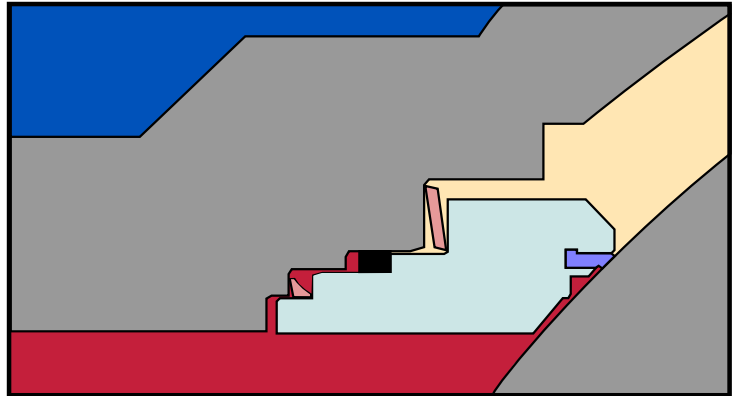

STANDARDS AND SPECIFICATIONS

DOUBLE ACTING - T32

SIZES

- 8 in. (200 mm) through 48 in. (1200 mm)

PRESSURE CLASSES

- ASME/ANSI Class 150 through 900 (PN 20 through PN 150)

OPERATING TEMPERATURES

- -50°F to 250°F (-46°C to 121°C)

METAL-TO-METAL - T34

SIZES

- 2 in. (50 mm) through 48 in. (1200 mm)

PRESSURE CLASSES

- ASME/ANSI Class 150 (PN 20) through API 10,000

OPERATING TEMPERATURES

- -50°F to 375°F (-46°C to 190°C)

FULLY WELDED BALL VALVES IN-LINE SPHERE LAUNCHER

Proven by years of service, the CAMERON in-line sphere launcher offers many advantages over traditional launcher systems.

FEATURES AND BENEFITS

COST EFFECTIVE

The launcher's unique design greatly reduces the cost of constructing a launching system.

This design combines three valves into one. A conventional design requires a main line block, launching and kicker valves.

The CAMERON in-line launcher does the job of both the main line block and the launching valve. The pig is inserted directly into the main flow line eliminating the need for a kicker valve. Eliminating the need for two valves and related piping supports produces an overall cost savings.

EASY INSTALLATION

The CAMERON design is simple and easy to install. In an existing gathering system, the CAMERON launching valve is easily inserted without major fabrication.

DOUBLES AS BLOCK VALVE

Because the launcher valve has all the features of a standard CAMERON Ball Valve, it can double as a main block valve in virtually any system.

FIELD PREFERRED

The speed and ease of the CAMERON launching system make it the preferred method among field personnel.

WIDE VARIETY OF SIZES AVAILABLE

The CAMERON launcher is available in sizes to accommodate spherical pigs from 2 in. to 30 in. (50 mm to 750 mm) in diameter.

ACCOMMODATES MULTIPLE SPHERES

The launcher can be built with an extended barrel, enabling the operator to stack multiple pigs in the barrel and launch them simply by operating the valve.

ADDITIONAL OPTIONS AVAILABLE

The following options can help tailor the launcher to a variety of applications: manual gear operators; pneumatic, hydraulic, gas over oil and electric operators; addition of pup pipe (transition pipe).



LAUNCHING SEQUENCE (TOP VIEW)

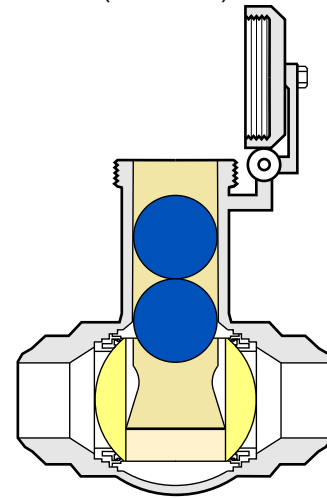

1. Valve is closed.
2. Valve body is vented.
3. Hinged door opens to load sphere.

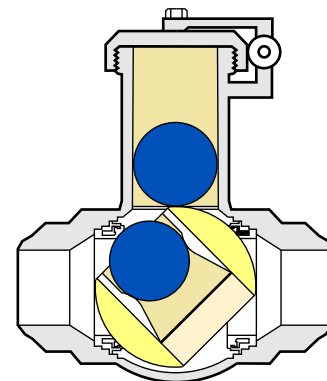

4. Extended barrel allows several spheres to be loaded.
5. Door is closed.
6. Valve body is re-energized.
7. Valve is opened.

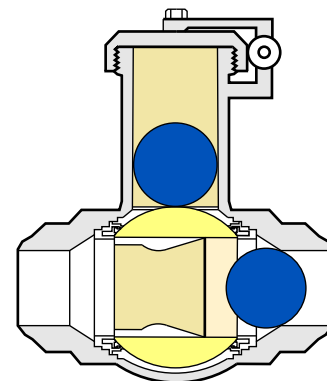

8. Spherical pig in launch position.

FULLY WELDED BALL VALVES ACCESSORIES

Quality CAMERON accessories are available to improve the CAMERON Fully Welded Ball Valve's adaptability to a wide variety of situations.

HIGH HEAD FOR REMOTE OPERATION
For situations in which the CAMERON Fully Welded Ball Valve must be underground, the CAMERON High Head makes the controls accessible above ground.

Designed and constructed to withstand punishing environments, it has proven itself in uses all over the world for many years.

SUBSEA DESIGN OFFERS IMPORTANT BENEFITS

For the same reliable performance offshore as on, the CAMERON Fully Welded Ball Valve is available with a coating and actuation designed specifically for the demands of a subsea environment.

RIGHT ANGLE IMPROVES FLEXIBILITY
CAMERON Fully Welded Ball Valves can be specified for tight spaces when fitted with a CAMERON Right Angle Extension. The valve control is turned 90 degrees from its usual position, allowing more space at the top of the valve and better access by operators.

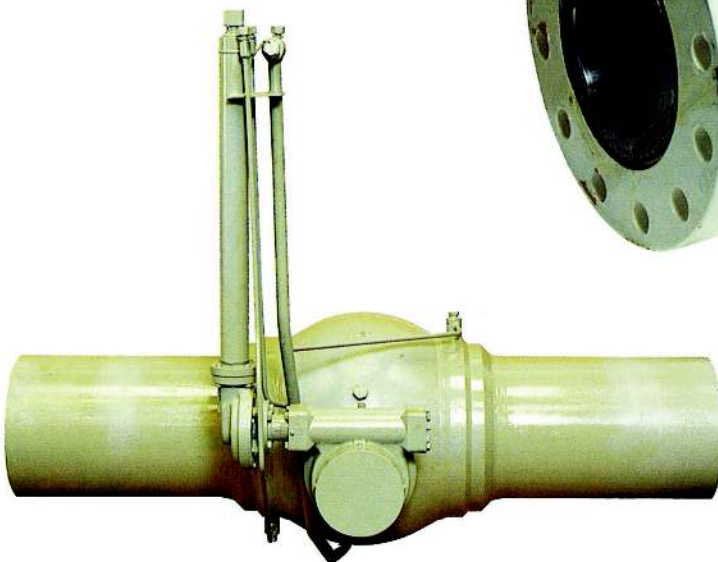

FULLY WELDED BALL VALVES HOW TO ORDER

SPECIFY THE FOLLOWING WHEN ORDERING
A CAMERON FULLY WELDED BALL VALVE:

1. Valve figure number (see chart below).
2. Pressure classification (ASME/ANSI 600 lb, API 3000 psi).
3. End and bore sizes.
4. Type of end connections (unequal ends can be furnished). For weld end valves, specify I.D. or O.D., wall thickness and grade of pipe.
5. Type of operator.
6. Stem extension, if desired. Specify distance from valve centerline to center of handwheel, or top of power operator mounting flange.
7. Type of trim or application.
8. Accessories, if desired (lifting eyes, locking devices, etc.). Handwheels are included with valves, but operating levers must be ordered separately. Information on special trims and API configurations is available upon request.

SPECIFY THE FOLLOWING WHEN ORDERING
ANOTHER MANUFACTURER'S POWER
OPERATOR TO FIT A CAMERON FULLY
WELDED BALL VALVE:

1. Valve size and pressure class and, if for field conversion, the present operator.
2. Maximum differential pressure across valve during operation and any abnormal operating conditions.
3. Speed of opening and closing, probable frequency of operation.
4. Type operator desired (electric, hydraulic, pneumatic).
5. Information on operating medium.
If electric;
voltage, frequency, single or three phase, open or explosion proof motor.
If hydraulic or pneumatic;
operating medium, pressure.
6. Accessories and controls;
limit switches, instrumentation, valving,

80	06	0	1	-	2	-	1
Classification	Pressure Classification	Bore	End Connections		Operator		Trim

80	ASME/ANSI
81	API
82	AFNOR
83	DIN
84	UNI

01	ASME/ANSI 150
03	ASME/ANSI 300
04	ASME/ANSI 400
06	ASME/ANSI 600
09	ASME/ANSI 900
15	ASME/ANSI 1500
25	ASME/ANSI 2500
20	API 2000
30	API 3000
50	API 5000

0	Full
7	Reduced
4	Venturi
9	All Others

1	RF/RF
2	WE/WE
3	RF/WE
4	RTJ/RTJ
5	RTJ/WE
9	All Others

1	Lever
1A	Extension Lever
2	Worm gear
2A	Extension Worm Gear
4	Subsea Gear
4A	Subsea Gear 300 feet +
7	Direct Stem
7A	Extension Direct Stem
8	Worm Gear/Adapted
8A	Extension Worm Gear/Adapted
22	Square
22A	Extension Square Nut/Mtg/Flg
23	Worm Gear with 2 inch Square Operating Nut
23A	Worm Gear with Right Angle Pinion Shaft Extension and 2 inch Square Operating Nut

1	Standard (150-1500)
2	Standard API (2000-5000)
4	Hi-Temp Teflon (150-600)
8	Lo-Temp Nylon (150-2500)
123	Pressure Regulating (150-1500)
212	NACE (150-2500)
213	NACE (2000-5000)
214	Tefzel/NACE (150-1500)
215	Tefzel/NACE (2000-5000)
216	NACE/Lo-Temp (150-2500)
217	NACE/Lo-Temp (2000-5000)
222	NACE/Hi-Temp (150-600)
259	NACE/316 Inlay (150-2500)

FULLY WELDED BALL VALVES STANDARDS, SPECIFICATIONS AND MATERIALS

CAMERON Fully Welded Ball Valves conform to one or more of the following specifications for pressure, temperature ratings and dimensions: ASME/ANSI, ISO 14313/API 6D, ISO 10423/API 6A, ISO 17423/API 6DSS, DIN, AFNOR, British Standards, ISO 9000 and API Q1.

TRIM MATERIALS FOR STANDARD VALVES

Pressure Range	ASME/ANSI Class 150-2500 (PN 20-PN 420)
Temperature Range	-20°F to 250°F (-29°C to 121°C)
Body	ASTM A350 Gr. LF-2(M)
End Connection	ASTM A350 Gr. LF-2(M)
Ball	ASTM A694 Gr. F50(M) Chrome Plated or ENP
Seat Ring	AISI 1040
Seat Load Spring	AISI 1040
Stem Seals	PTFE
Lip Seals	PTFE
Seat Ring Insert	Nylon

Other trims are available upon request.

OPTIONAL TRIM MATERIALS

Trim	Pressure Rating	Temperature Rating	Trim Numbers	
			Regular	Corrosion Resistant (NACE MR0175)
Standard	ASME/ANSI Class 150 - 2500	-20°F to 250°F (-29°C to 121°C)	1	212
	API 2000-5000	-20°F to 250°F (-29°C to 121°C)	2	213
Low Temperature	ASME/ANSI Class 150 - 2500	-50°F to 250°F (-46°C to 121°C)	8	216
	API 2000-5000	-50°F to 250°F (-46°C to 121°C)	-	217
High Temperature	ASME/ANSI Class 150 - 600	-20°F to 375°F (-29°C to 190°C)	4	222
Tefzel (Acidizing)	ASME/ANSI Class 150 - 1500	-20°F to 300°F (-29°C to 149°C)	140	214
	API 2000-5000	-20°F to 300°F (-29°C to 149°C)	108	215
Tefzel Low Temperature	ASME/ANSI Class 150 - 1500	-50°F to 300°F (-46°C to 149°C)	223	-
	API 2000-5000	-50°F to 300°F (-46°C to 149°C)	-	-
Duplex (Internal) Stainless Steel	ASME/ANSI Class 150 - 1500	-20°F to 250°F (-29°C to 121°C)	-	276
Full Duplex Stainless Steel	ASME/ANSI Class 150 - 1500	-50°F to 250°F (-46°C to 121°C)	-	504

MATERIALS

Materials used in ball valve construction are broadly equivalent at all Cameron's Valves & Measurement group manufacturing plants. However, the availability of local supplies, the need to conform to national standards and to offer various trims may necessitate some variations. In corrosive applications, valve trims may be offered using various types of alloys and stainless steels. For more information on material specifications and properties, please contact your local Cameron's Valves & Measurement group representative.

TORQUE INFORMATION

Please contact your CAMERON Valves representative to obtain a copy of the engineering bulletin which provides detailed torque information for sizing of power actuators.

DIMENSIONAL CODES FOR FLANGED AND WELD ENDS (FULL & REDUCED OPENINGS)

CODE IDENTIFICATION:

- A End to end (length dimension)
- B Bore diameter
- C Centerline to bottom
- D1 Flange outside diameter
- D2 Flange inside dimension
- E Sphere dimension

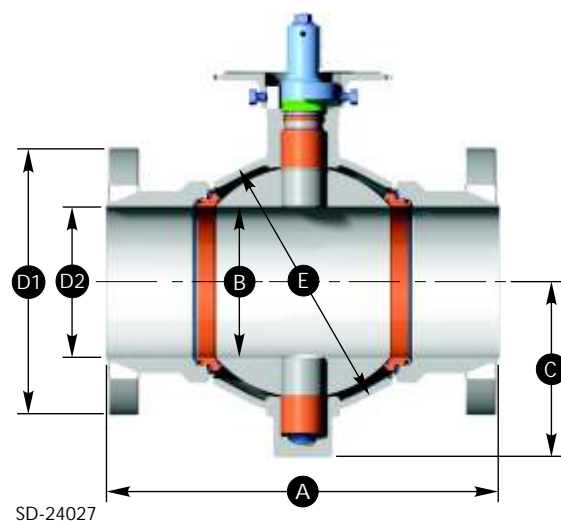

DIMENSIONAL CODES FOR CAMERON MANUAL OPERATORS

CODE IDENTIFICATION:

- G Handwheel diameter
- H Center of bore to top of square nut for lever operated valves, center of bore to handwheel for gear operated valves
- L Center of bore to end of lever

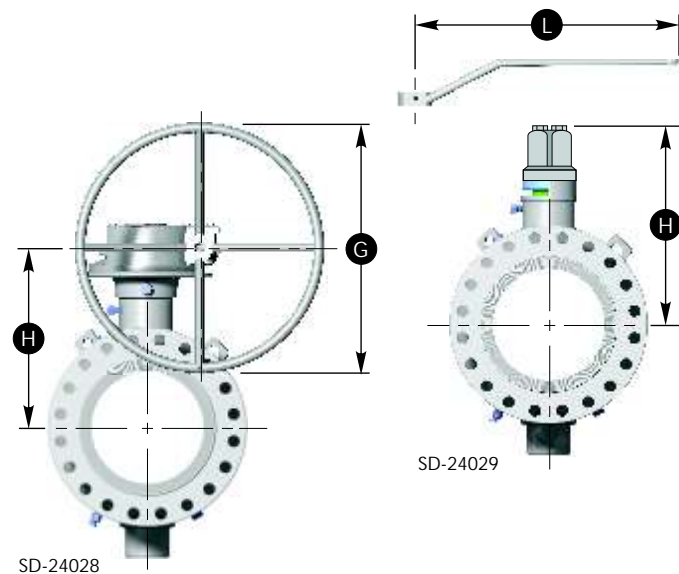

FULLY WELDED BALL VALVES - FULL BORE ASME/ANSI CLASS 150 (PN 20)

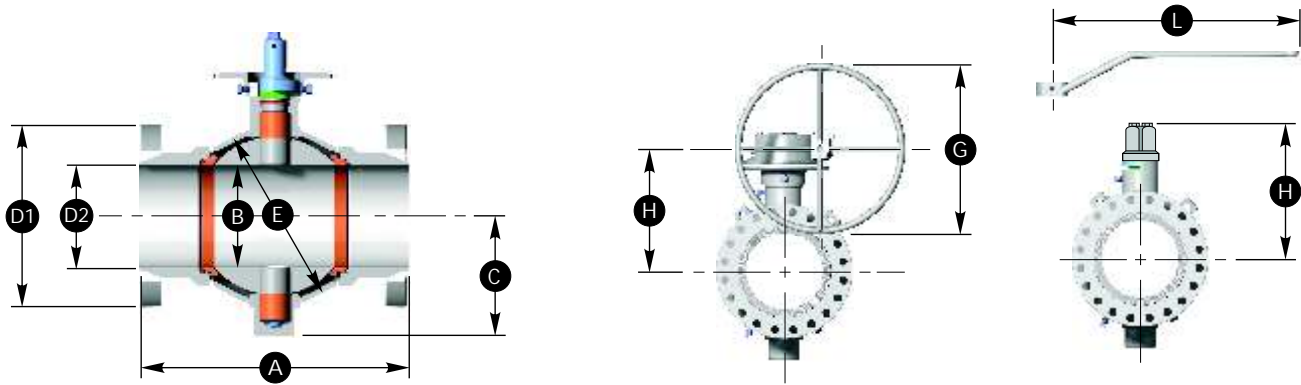

DIMENSIONS

SIZE in.			Flanged End				Weld End Length A	C.L. to Bottom C	Body Sphere E	Lever Length L	Diameter Handwheel for Gear G	C.L. to Handwheel C.L. H	Approximate Valve Weight lb.	
Nom Dia.	Ball Bore B	Stem Size	RF Length A	RTJ Length A	Dia. D1 ¹⁾	Dia. D2							Flange	Weld
2	2.06	1.0	7.0	7.5	6.00	2.06	11.0 \square	3.94	5.00	24	-	6.34	39	45
3	3.13	1.0	8.0	8.5	7.50	3.13	12.5 \square	5.12	6.75	24	-	7.44	62	75
4	4.06	1.5	9.0	9.5	9.00	4.06	14.0	5.94	8.50	36	-	8.43	115	100
6	6.00	1.5	15.5	16.0	11.00	6.00	18.0	7.91	11.25	36	-	10.43	200	225
8	8.00	2.0	18.0	18.5	13.50	8.00	21.5 \square	10.00	15.50	-	18	12.55	428	450
10	10.00	2.0	21.0	21.5	16.00	10.00	23.5 \square	12.12	18.50	-	18	14.54	705	650
12	12.00	3.0	24.0	24.5	19.00	12.00	26.5 \square	14.50	22.36	-	18	20.14	1210	1100
14	13.25	3.0	27.0	27.5	21.00	13.25	28.5*	14.64	24.00	-	24	21.16	1330	1230
16	15.25	3.0	30.0	30.5	23.50	15.25	30.5*	16.01	26.32	-	24	22.52	1650	1550
18	17.25	4.0	34.0	34.5	25.00	17.25	33.5*	19.25	29.20	-	24	26.19	2325	2200
20	19.25	4.0	36.0	36.5	27.50	19.25	35.5*	20.81	32.27	-	18	27.75	3310	2760
22	21.25	4.0	40.0	40.5	29.50	21.25	38.5*	22.28	36.00	-	18	29.22	3875	3510
24	23.25	4.0	42.0	42.5	32.00	23.25	42.0*	23.69	38.76	-	18	30.63	4620	4260
26	25.00	5.0	45.0	-	34.25	25.00	44.5*	26.49	41.75	-	24	34.34	6400	5600
28	27.00	5.0	49.0	-	36.50	27.00	47.0*	27.88	44.86	-	24	35.72	7200	6500
30	29.00	5.0	51.0	-	38.75	29.00	49.0*	29.51	47.90	-	24	37.37	9500	8800
34	32.75	5.0	58.0	-	43.75	32.75	54.5*	32.16	53.64	-	30	40.01	13500	12000
36	34.50	5.0	60.0	-	46.00	34.50	56.5*	33.76	56.83	-	36	41.60	15150	14500
40	38.50	7.5	69.0	-	50.75	38.50	65.0*	40.14	65.00	-	30	50.25	-	-
42	41.25	7.5	72.0	-	53.00	41.25	66.5*	41.78	68.60	-	42	51.89	-	-
48	46.50	7.5	80.0	-	59.50	46.50	76.0*	45.90	77.00	-	-	-	-	-
SIZE mm												kg		
50	52	25	178	191	152	52	279 \square	100	127	610	-	161	18	20
80	80	25	203	216	191	80	318 \square	130	171	610	-	189	28	34
100	103	38	229	241	229	103	356	151	216	914	-	214	52	45
150	152	38	394	406	279	152	457	201	286	914	-	265	91	102
200	203	51	457	470	343	203	546 \square	254	394	-	457	319	194	204
250	254	51	533	546	406	254	597 \square	308	470	-	457	369	320	295
300	305	76	610	622	483	305	673 \square	368	568	-	457	512	549	499
350	337	76	686	699	533	337	724*	372	610	-	610	537	603	558
400	387	76	762	775	597	387	775*	407	669	-	610	572	748	703
450	438	102	864	876	635	438	851	489	742	-	610	665	1055	998
500	489	102	914	927	699	489	902	529	820	-	457	705	1501	1252
550	540	102	1016	1029	749	540	978*	566	914	-	457	742	1758	1592
600	591	102	1067	1080	813	591	1067*	602	985	-	457	778	2096	1932
650	635	127	1143	-	870	635	1130*	673	1060	-	610	872	2903	2540
700	686	127	1245	-	927	686	1194*	708	1139	-	610	907	3266	2948
750	737	127	1295	-	984	737	1245*	750	1217	-	610	949	4309	3992
850	832	127	1473	-	1111	832	1384*	817	1362	-	762	1016	6123	5443
900	876	127	1524	-	1168	876	1435*	858	1443	-	914	1057	6872	6577
1000	978	191	1753	-	1289	978	1651*	1020	1651	-	762	1276	-	-
1050	1048	191	1829	-	1346	1048	1689*	1061	1742	-	1067	1318	-	-

Length (A) of a weld x flanged end valve is one half the sum of length (A) of a weld end and a flange end of the same size and rating.

* Short pattern.

\square Length exceeds specified dimensions in API 6D/ISO 14313.

¹⁾ Dimensions of 22 in. (550 mm) flanges are per MSS-SP-44 and 26 in. (650 mm) through 42 in. (1050 mm) flanges are per ASME B16.47 Series A.

FULLY WELDED BALL VALVES REDUCED BORE ASME/ANSI CLASS 150 (PN 20)

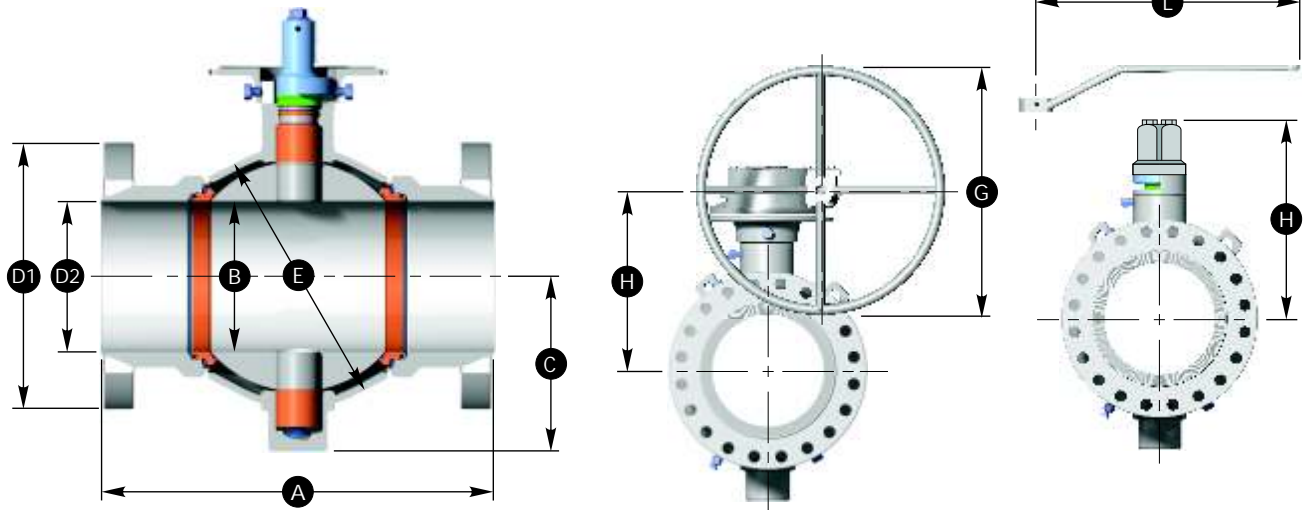

DIMENSIONS

SIZE in.	Ball Bore B	Stem Size	RF Length A	Flanged End RTJ Length A	Dia. D1 ¹⁾	Dia. D2	C.L. Weld End Length A	to Bottom C	Body Sphere E	Diameter Lever Length L	C.L. to Handwheel for Gear G	Approximate Handwheel C.L. H	Approximate Valve Weight lb.	Flange	Weld
3	2.06	1.0	8.0	8.5	7.50	3.13	11.0 \square	3.94	5.00	24	-	6.34	55	50	
4	3.13	1.0	9.0	9.5	9.00	4.06	12.5 \square	5.12	6.75	24	-	7.44	100	87	
6	4.06	1.5	15.5	16.0	11.00	6.00	14.0 \square	5.94	8.50	36	-	8.43	170	150	
8	6.00	1.5	18.0	18.5	13.50	8.00	18.0	7.91	11.25	36	-	10.43	345	290	
10	8.00	2.0	21.0	21.5	16.00	10.00	21.5 \square	10.00	15.50	-	18	12.55	620	525	
12	10.00	2.0	24.0	24.5	19.00	12.00	23.5 \square	12.12	18.50	-	18	14.54	950	840	
14	12.00	3.0	27.0	27.5	21.00	13.25	26.5 \square	14.50	22.36	-	18	20.14	1280	1160	
16	13.25	3.0	30.0	30.5	23.50	15.25	28.5*	14.64	24.00	-	24	21.16	1450	1330	
18	15.25	3.0	34.0	34.5	25.00	17.25	30.5*	16.01	26.32	-	24	22.52	1510	1700	
20	17.25	4.0	36.0	36.5	27.50	19.25	33.5*	19.25	29.20	-	24	26.19	2410	2300	
22	19.25	4.0	40.0	40.5	29.50	21.25	35.5*	20.81	32.27	-	18	27.75	3450	3050	
24	21.25	4.0	42.0	42.5	32.00	23.25	38.5*	22.28	36.00	-	18	29.22	4300	3650	
26	23.25	4.0	45.0	-	34.25	25.00	42.0*	23.69	38.76	-	18	30.63	5400	5100	
28	25.00	5.0	49.0	-	36.50	27.00	44.5*	26.49	41.75	-	24	34.34	7040	6100	
30	27.00	5.0	51.0	-	38.75	29.00	47.0*	27.88	44.86	-	24	35.72	8900	7600	
32	29.00	5.0	54.0	-	41.75	32.75	49.0*	29.51	47.90	-	24	37.37	9600	8500	
36	32.75	5.0	60.0	-	46.00	34.50	54.5*	32.16	53.64	-	30	40.01	14000	12500	
42	34.50	5.0	72.0	-	53.00	41.25	56.5*	33.76	56.83	-	36	41.60	-	-	
SIZE mm															kg
80	52	25	203	216	191	80	279 \square	100	127	610	-	161	25	23	
100	80	25	229	241	229	103	318 \square	130	172	610	-	189	45	39	
150	103	38	394	406	279	152	356 \square	151	216	914	-	214	77	68	
200	152	38	457	470	343	203	457	201	286	914	-	265	156	132	
250	203	51	533	546	406	254	564 \square	254	394	-	457	319	281	238	
300	254	51	610	622	483	305	597 \square	308	470	-	457	369	431	381	
350	305	76	686	699	533	337	673 \square	368	568	-	457	512	581	526	
400	337	76	762	775	597	387	724*	372	610	-	609	537	658	603	
450	387	76	864	876	635	438	774*	407	669	-	609	572	685	771	
500	438	102	914	927	699	489	851*	489	741	-	609	665	1093	1043	
550	489	102	1016	1029	749	540	902*	529	820	-	457	705	1565	1383	
600	540	102	1067	1080	813	591	978*	566	914	-	457	742	1950	1656	
650	591	102	1143	-	870	635	1067*	602	985	-	457	778	2449	2313	
700	635	127	1245	-	927	686	1130*	673	1061	-	609	872	3193	2767	
750	686	127	1295	-	984	737	1194*	708	1139	-	609	907	4037	3447	
800	737	127	1372	-	1048	832	1245*	750	1217	-	609	949	4355	3856	
900	832	127	1524	-	1168	876	1384*	817	1363	-	762	1016	6350	5670	

Length (A) of a weld x flanged end valve is one half the sum of length (A) of a weld end and a flange end of the same size and rating.

* Short pattern.

\square Length exceeds specified dimensions in API 6D/ISO 14313.

¹⁾ Dimensions of 22 in. (550 mm) flanges are per MSS-SP-44 and 26 in. (650 mm) through 42 in. (1050 mm) flanges are per ASME B16.47 Series A.

Note: Venturi opening or other reduced bore valves are available upon request.

FULLY WELDED BALL VALVES - FULL BORE ASME/ANSI CLASS 300 (PN 50)

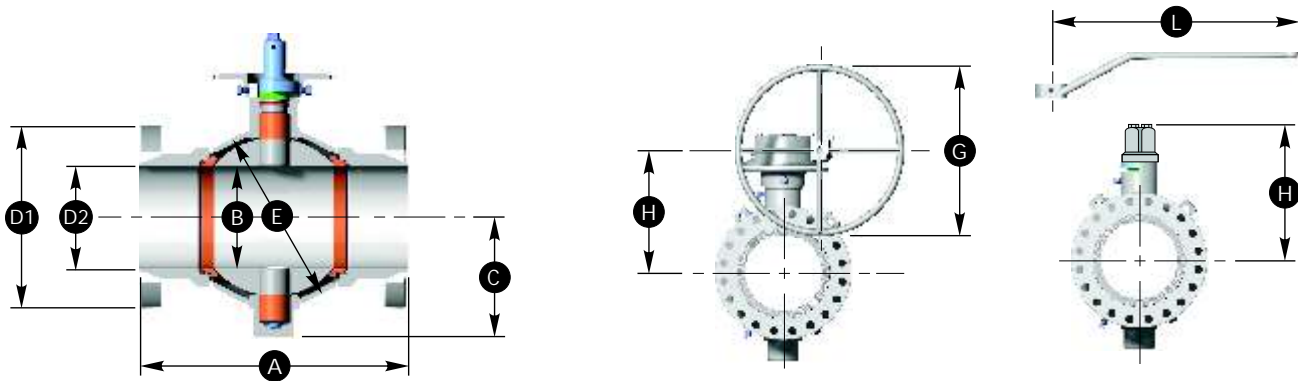

DIMENSIONS

SIZE in.	Ball Bore B	Stem Size	RF Length A	Flanged End RTJ Length A	Dia. D1 ¹⁾	Dia. D2	Weld End Length A	C.L. to Bottom C	Body Sphere E	Lever Length L	Diameter Handwheel for Gear G	C.L. to Handwheel C.L. H	Approximate Valve Weight lb.		
Nom Dia.	B						A	C	E	L	G	H	Flange	Weld	
2	2.06	1.0	8.50	9.125	6.50	2.06	11.0 \square	3.94	5.00	24	-	6.34	50	45	
3	3.13	1.0	11.125	11.750	8.25	3.13	12.5 \square	5.12	6.75	24	-	7.44	80	75	
4	4.06	1.5	12.00	12.625	10.00	4.06	14.0 \square	5.94	8.50	36	-	8.43	125	100	
6	6.00	1.5	15.875	16.500	12.50	6.00	18.0	7.91	11.25	36	-	10.43	250	225	
8	8.00	2.0	19.75**	20.375	15.00	8.00	21.5 \square	10.00	15.50	-	18	12.55	455	450	
10	10.00	2.0	22.375	23.000	17.50	10.00	23.5 \square	12.12	18.50	-	24	14.54	750	650	
12	12.00	3.0	25.50	26.125	20.50	12.00	26.5 \square	14.50	22.36	-	18	20.14	1275	1100	
14	13.25	3.0	30.00	30.625	23.00	13.25	28.5*	14.64	24.00	-	24	21.16	1370	1230	
16	15.25	3.0	33.00	33.625	25.50	15.25	30.5*	16.01	26.32	-	24	22.52	1725	1550	
18	17.25	4.0	36.00	36.625	28.00	17.25	33.5*	19.25	29.20	-	24	26.19	2700	2200	
20	19.25	4.0	39.00	39.750	30.50	19.25	35.5*	20.81	32.27	-	18	27.75	3400	2760	
22	21.25	4.0	43.00	43.875	33.00	21.25	38.5*	22.28	36.00	-	24	29.22	4050	3510	
24	23.25	4.0	45.00	45.875	36.00	23.25	42.0*	23.69	38.76	-	24	30.63	5390	4260	
26	25.00	5.0	49.00	50.000	38.25	25.00	44.5*	26.49	41.75	-	24	34.34	6625	5600	
28	27.00	5.0	53.00	54.000	40.75	27.00	47.0*	27.88	44.86	-	24	35.72	7725	6500	
30	29.00	5.0	55.00	56.000	43.00	29.00	49.0*	29.51	47.90	-	30	37.37	10000	8800	
34	32.75	5.0	64.00	65.125	47.50	32.75	54.5*	32.16	53.64	-	36	40.01	14700	12000	
36	34.50	7.5	68.00	69.125	50.00	34.50	56.5*	36.80	56.83	-	24	46.92	16300	15500	
40	38.50	7.5	74.00	-	48.75	38.50	65.0*	40.14	65.00	-	36	50.25	-	-	
42	41.25	7.5	76.00	-	50.75	41.25	66.5*	41.78	68.60	-	42	51.89	-	-	
48	46.50	7.5	86.00	-	57.75	46.50	76.0*	45.90	77.00	-	-	-	-	-	
SIZE mm														kg	
50	52	25	216	232	165	52	279 \square	100	127	610	-	161	23	20	
80	80	25	283	298	210	80	318 \square	130	172	610	-	189	36	34	
100	103	38	305	321	254	103	356 \square	151	216	914	-	214	57	45	
150	152	38	403	419	318	152	457	201	286	914	-	265	113	102	
200	203	51	502**	518	381	203	546 \square	254	394	-	457	319	206	204	
250	254	51	568	584	445	254	597 \square	308	470	-	610	369	340	295	
300	305	76	648	664	521	305	673 \square	368	568	-	457	512	578	499	
350	337	76	762	778	584	337	724*	372	610	-	610	537	621	558	
400	387	76	838	854	648	387	775*	407	669	-	610	572	782	703	
450	438	102	914	930	711	438	851*	489	742	-	610	665	1225	998	
500	489	102	991	1010	775	489	902*	529	820	-	457	705	1542	1252	
550	540	102	1092	1114	838	540	978*	566	914	-	610	742	1837	1592	
600	591	102	1143	1165	914	591	1067*	602	985	-	609	778	2445	1932	
650	635	127	1245	1270	972	635	1130*	673	1060	-	610	872	3005	2540	
700	686	127	1346	1372	1035	686	1194*	708	1139	-	610	907	3504	2948	
750	737	127	1397	1422	1092	737	1245*	750	1217	-	762	949	4536	3992	
850	832	127	1626	1654	1207	832	1384*	817	1362	-	914	1016	6668	5443	
900	876	191	1727	1756	1270	876	1435*	935	1443	-	610	1192	7394	7031	
1000	978	191	1880	-	1238	978	1651*	1020	1651	-	914	1276	-	-	
1050	1048	191	1930	-	1289	1048	1689*	1061	1742	-	1067	1318	-	-	

Length (A) of a weld x flanged end valve is one half the sum of length (A) of a weld end and a flanged end of the same size and rating.

* Short pattern.

\square Length exceeds specified dimensions in API 6D/ISO 14313.

¹⁾ Dimensions of 22 in. (550 mm) flanges are per MSS-SP-44 and 26 in. (650 mm) through 42 in. (1050 mm) flanges are per ASME B16.47 Series A.

** Prior to 1/1/98 - manufactured to 16.5 in. (419 mm) short pattern length.

FULLY WELDED BALL VALVES REDUCED BORE ASME/ANSI CLASS 300 (PN 50)

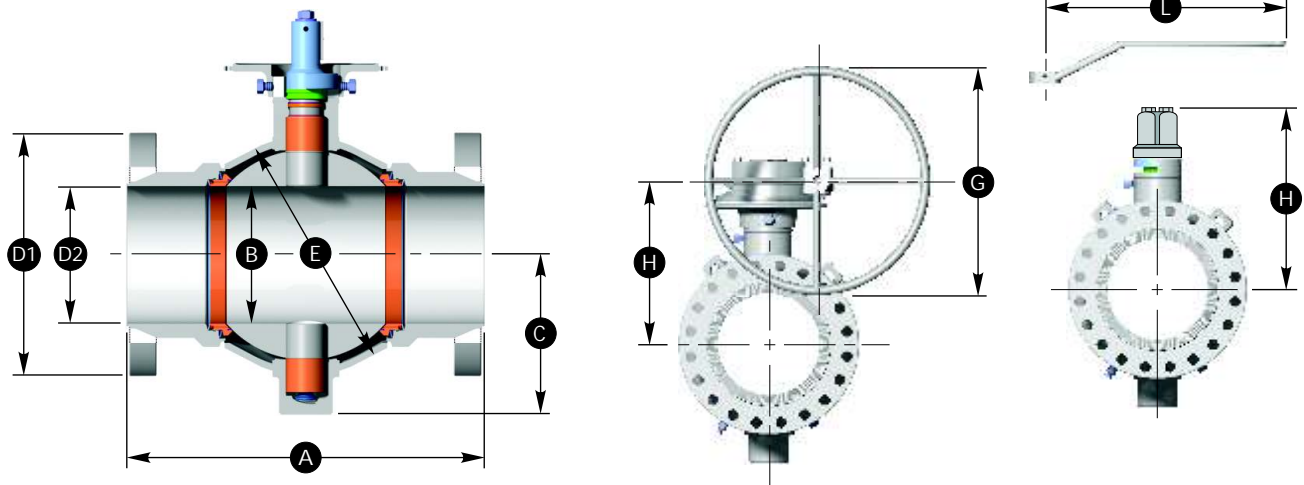

DIMENSIONS

SIZE in.	Ball Bore B	Stem Size	Flanged End			Weld End Length A	C.L. to Bottom C	Body Sphere E	Lever Length L	Diameter Handwheel for Gear G	C.L. to Handwheel C.L. H	Approximate Valve Weight lb.		
Nom Dia.	B		RF Length A	RTJ Length A	Dia. D1 ¹⁾	Dia. D2					Flange	Weld		
3	2.06	1.0	11.125	11.75	8.25	3.13	11.0*	3.94	5.00	24	-	6.34	64	50
4	3.13	1.0	12.00	12.625	10.00	4.06	12.5 [⊠]	5.12	6.75	24	-	7.44	95	87
6	4.06	1.5	15.875	16.500	12.50	6.00	14.0*	5.94	8.50	36	-	8.43	180	150
8	6.00	1.5	19.75**	20.375	15.00	8.00	18.0*	7.91	11.25	36	-	10.43	365	290
10	8.00	2.0	22.375	23.000	17.50	10.00	21.5*	10.00	15.50	-	18	12.55	650	525
12	10.00	2.0	25.50	26.125	20.50	12.00	23.5*	12.12	18.50	-	24	14.54	1050	840
14	12.00	3.0	30.00	30.625	23.00	13.25	26.5*	14.50	22.36	-	18	20.14	1285	1160
16	13.25	3.0	33.00	33.625	25.50	15.25	28.5*	14.64	24.00	-	24	21.16	1660	1330
18	15.25	3.0	36.00	36.625	28.00	17.25	30.5*	16.01	26.32	-	24	22.52	1990	1700
20	17.25	4.0	39.00	39.750	30.50	19.25	33.5*	19.25	29.20	-	24	26.19	3100	2300
22	19.25	4.0	43.00	43.875	33.00	21.25	33.5*	20.81	32.27	-	18	27.75	3600	3050
24	21.25	4.0	45.00	45.875	36.00	23.25	38.5*	22.28	36.00	-	24	29.22	4500	3650
26	23.25	4.0	49.00	50.000	38.25	25.00	42.0*	23.69	38.76	-	24	30.63	5750	5100
28	25.00	5.0	53.00	54.000	40.75	27.00	44.5*	26.49	41.75	-	24	34.34	7260	6100
30	27.00	5.0	55.00	56.000	43.00	29.00	47.0*	27.88	44.86	-	24	35.72	9100	7600
32	29.00	5.0	60.00	61.125	45.25	32.75	49.0*	29.51	47.90	-	30	37.37	10150	8800
36	32.75	5.0	68.00	69.125	50.00	34.50	54.5*	32.16	53.64	-	36	40.01	15350	13000
42	34.50	7.5	76.00	-	50.75	41.25	56.5*	36.80	56.83	-	24	49.92	-	-
SIZE mm												kg		
80	52	25	283	298	210	80	279*	100	127	610	-	161	29	23
100	80	25	305	321	254	103	318 [⊠]	130	171	610	-	189	43	39
150	103	38	403	419	318	152	356*	151	216	914	-	214	82	68
200	152	38	502**	518	381	203	457*	201	286	914	-	265	166	132
250	203	51	568	584	445	254	546*	254	394	-	457	319	295	238
300	254	51	648	664	521	305	597*	308	470	-	610	369	476	381
350	305	76	762	778	584	337	673*	368	568	-	457	512	583	526
400	337	76	838	854	648	387	724*	372	610	-	610	537	753	603
450	387	76	914	930	711	438	775*	407	669	-	610	572	903	771
500	438	102	991	1010	775	489	851*	489	742	-	610	665	1406	1043
550	489	102	1092	1114	838	540	851*	529	820	-	457	705	1633	1383
600	540	102	1143	1165	914	591	978*	566	914	-	610	742	2041	1656
650	591	102	1245	1270	972	635	1067*	602	985	-	610	778	2608	2313
700	635	127	1346	1372	1035	686	1130*	673	1060	-	610	872	3293	2767
750	686	127	1397	1422	1092	737	1194*	708	1139	-	610	907	4128	3447
800	737	127	1524	1553	1149	832	1245*	750	1217	-	762	949	4604	3992
900	832	127	1727	1756	1270	867	1384*	817	1362	-	914	1016	6963	5897

Length (A) of a weld x flanged end valve is one half the sum of length (A) of a weld end and a flange end of the same size and rating.

* Short pattern.

[⊠] Length exceeds specified dimensions in API 6D/ISO 14313.

¹⁾ Dimensions of 22 in. (550 mm) flanges are per MSS-SP-44 and 26 in. (650 mm) through 42 in. (1050 mm) flanges are per ASME B16.47 Series A.

** Prior to 1/1/98 - manufactured to 16.5 in. (419 mm) short pattern length.

Note: Venturi opening or other reduced bore valves are available upon request.

FULLY WELDED BALL VALVES FULL BORE ASME/ANSI CLASS 400 (PN 64)

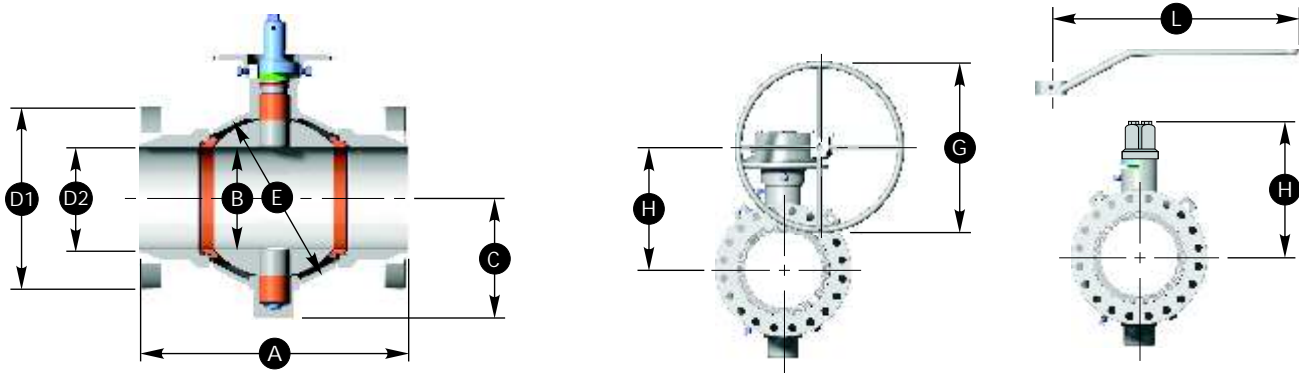

DIMENSIONS

SIZE in.	Ball Bore B	Stem Size	Flanged End		Weld End Length A	C.L. to Bottom C	Body Sphere E	Lever Length L	Diameter Handwheel for Gear G	C.L. to Handwheel C.L. H	Approximate Valve Weight lb.			
Nom Dia.	B		RF Length A	RTJ Length A							Flange	Weld		
2	2.06	Use ASME/ANSI Class 600 Valves (PN 100)												
3	3.13	Use ASME/ANSI Class 600 Valves (PN 100)												
4	4.06	1.5	16.0	16.125	10.00	4.06	14.0*	5.94	8.50	36	-	8.43	150	100
6	6.00	1.5	19.5	19.625	12.50	6.00	18.0*	7.91	11.25	36	-	10.43	300	225
8	8.00	2.0	23.5	23.625	15.00	8.00	21.5*	10.00	15.50	-	18	12.55	550	450
10	10.00	2.0	26.5	26.625	17.50	10.00	23.5*	12.12	18.50	-	24	14.54	850	650
12	12.00	3.0	30.0	30.125	20.50	12.00	26.5*	14.50	22.36	-	18	20.14	1400	1100
14	13.25	3.0	32.5	32.625	23.00	13.25	28.5*	14.64	24.00	-	18	21.16	1650	1230
16	15.25	4.0	35.5	35.625	25.50	15.25	30.5*	17.84	26.32	-	18	24.78	2225	1770
18	17.25	4.0	38.5	38.625	28.00	17.25	33.5*	19.25	29.20	-	24	26.19	2850	2200
20	19.25	5.0	41.5	41.750	30.50	19.25	35.5*	22.11	32.27	-	24	30.00	3750	3000
22	21.25	5.0	45.0	45.375	33.00	21.25	38.5*	23.63	36.00	-	24	31.53	4750	3950
24	23.25	5.0	48.5	48.875	36.00	23.25	42.0*	25.05	38.76	-	24	32.95	5600	4750
26	25.00	5.0	51.5	52.000	38.25	25.00	44.5*	26.49	41.75	-	24	34.34	7100	5600
28	27.00	5.0	55.0	55.500	40.75	27.00	47.0*	27.88	44.86	-	30	35.72	8560	6500
30	29.00	5.0	60.0	60.500	43.00	29.00	49.0*	29.51	47.90	-	36	37.37	10600	8800
34	32.75	7.5	70.0	70.625	47.50	32.75	54.5*	35.19	53.64	-	30	45.31	15400	12300
36	34.50	7.5	74.0	74.625	50.00	34.50	56.5*	36.80	56.83	-	30	46.92	18000	15500
40	38.50	7.5	78.0	-	50.00	38.50	65.0*	40.14	65.00	-	42	50.25	25500	22250
42	41.25	7.5	81.0	-	52.00	41.25	66.5*	41.78	68.60	-	42	51.89	28750	24750
48	46.50	9.0	91.0	-	59.50	46.50	76.0*	47.98	77.00	-	-	-	-	-
SIZE mm											kg			
50	52	Use ASME/ANSI Class 600 Valves (PN 100)												
80	80	Use ASME/ANSI Class 600 Valves (PN 100)												
100	103	38	406	410	254	103	356*	151	216	914	-	214	68	45
150	152	38	495	498	318	152	457*	201	286	914	-	265	136	102
200	203	51	597	600	381	203	546*	254	394	-	457	319	249	204
250	254	51	673	676	445	254	597*	308	470	-	610	369	386	295
300	305	76	762	765	521	305	673*	368	568	-	457	512	635	499
350	337	76	826	829	584	337	724*	372	610	-	457	537	748	558
400	387	102	902	905	648	387	775*	453	669	-	457	629	1009	803
450	438	102	978	981	711	438	851*	489	742	-	610	665	1293	998
500	489	127	1054	1060	775	489	902*	562	820	-	610	762	1701	1361
550	540	127	1143	1153	838	540	978*	600	914	-	610	801	2155	1792
600	591	127	1232	1241	914	591	1067*	636	985	-	610	837	2540	2155
650	635	127	1308	1321	9712	635	1130*	673	1060	-	610	872	3221	2540
700	686	127	1397	1410	1035	686	1194*	708	1139	-	762	907	3883	2948
750	737	127	1524	1537	1092	737	1245*	750	1217	-	914	949	4808	3992
850	832	191	1778	1794	1207	832	1384*	894	1362	-	762	1151	6985	5579
900	876	191	1880	1895	1270	876	1435*	935	1443	-	762	1192	8165	7031
1000	978	191	1981	-	1270	978	1651*	1020	1651	-	1067	1276	11567	10092
1050	1048	191	2057	-	1321	1048	1689*	1061	1742	-	1067	1318	13041	11226

Length (A) of a weld x flanged end valve is one half the sum of length (A) of a weld end and a flange end of the same size and rating.

* Short pattern.

‡) Dimensions of 22 in. (550 mm) flanges are per MSS-SP-44 and 26 in. (650 mm) through 42 in. (1050 mm) flanges are per ASME B16.47 Series A.

FULLY WELDED BALL VALVES REDUCED BORE ASME/ANSI CLASS 400 (PN 64)

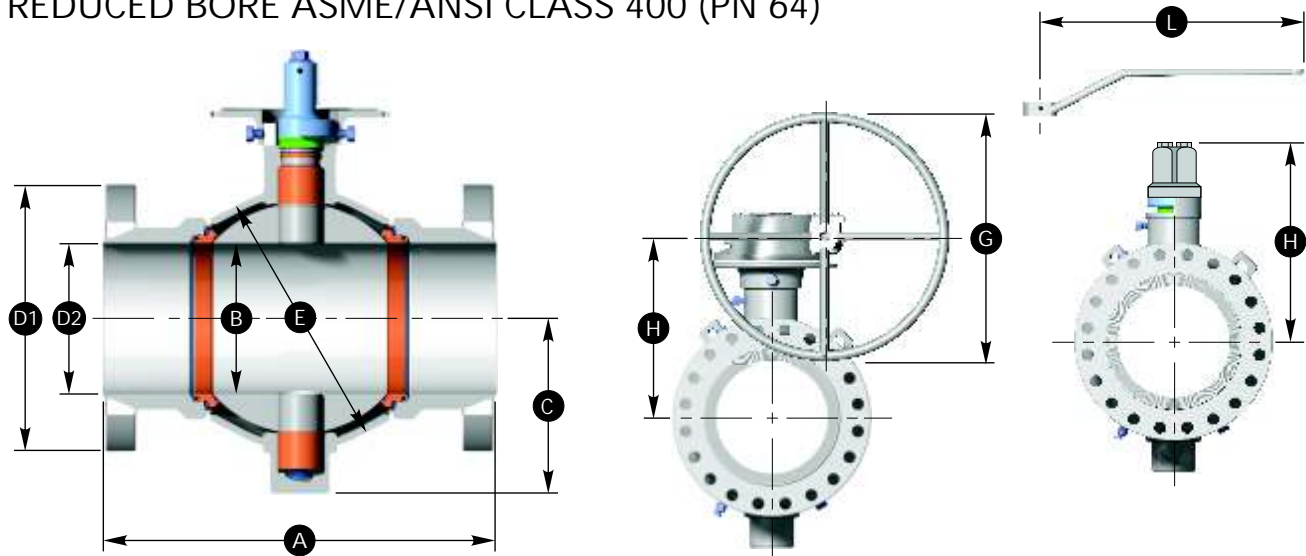

DIMENSIONS

SIZE in.		Ball Bore B	Stem Size	Flanged End		Weld End Length A	C.L. to Bottom C	Body Sphere E	Lever Length L	Diameter Handwheel for Gear G	C.L. to Handwheel C.L. H		Approximate Valve Weight lb.			
Nom Dia.	RF Length A			RTJ Length A	Dia. D1 ¹⁾						Dia. D2	Flange	Weld			
3	2.06	Use ASME/ANSI Class 600 Valves (PN 100)														
4	3.13	1.0	16.0	16.125	10.00	4.06	12.5*	5.12	6.75	24	-	7.44	125	87		
6	4.06	1.5	19.5	19.625	12.50	6.00	14.0*	5.94	8.50	36	-	8.43	189	150		
8	6.00	1.5	23.5	23.625	15.00	8.00	18.0*	7.91	11.25	-	18	10.43	424	290		
10	8.00	2.0	26.5	26.625	17.50	10.00	21.5*	10.00	15.50	-	18	12.55	608	525		
12	10.00	2.0	30.0	30.125	20.50	12.00	23.5*	12.12	18.50	-	24	14.54	1020	840		
14	12.00	3.0	32.5	32.625	23.00	13.25	26.5*	14.50	22.36	-	18	20.14	1490	1160		
16	13.25	3.0	35.5	35.625	25.25	15.25	28.5*	14.64	24.00	-	18	21.16	1910	1330		
18	15.25	4.0	38.5	38.625	28.00	17.25	30.5*	17.84	36.32	-	18	24.78	2400	1920		
20	17.25	4.0	41.5	41.750	30.50	19.25	33.5*	19.25	29.20	-	24	26.19	3200	2650		
22	19.25	5.0	45.0	45.375	33.00	21.25	35.5*	22.11	32.27	-	24	30.00	4250	3300		
24	21.25	5.0	48.5	48.875	36.00	23.25	38.5*	23.63	36.00	-	24	31.53	5050	4300		
26	23.25	5.0	51.5	52.000	38.25	25.00	42.0*	25.05	38.76	-	24	32.95	6250	5100		
28	25.00	5.0	55.0	55.500	40.75	27.00	44.5*	26.49	41.75	-	24	34.34	7750	6100		
30	27.00	5.0	60.0	60.500	43.00	29.00	47.0*	27.88	44.86	-	30	35.72	9500	7600		
32	29.00	5.0	65.0	65.625	45.25	32.75	49.0*	29.51	47.90	-	36	37.37	11500	9350		
36	32.75	7.5	74.0	74.625	50.00	34.50	54.5*	35.19	53.64	-	30	45.31	16000	13000		
42	34.50	7.5	81.0	-	52.00	41.25	56.5*	36.80	56.83	-	30	46.92	-	-		
SIZE mm																kg
80	52	Use ASME/ANSI Class 600 Valves (PN 100)														
100	80	25	406	410	254	103	318*	130	171	610	-	189	57	39		
150	103	38	495	498	318	152	356*	151	216	914	-	214	86	68		
200	152	38	597	600	381	203	457*	201	286	-	457	265	192	132		
250	203	51	673	676	445	254	546*	254	394	-	457	319	276	238		
300	254	51	762	765	521	305	597*	308	470	-	610	369	463	381		
350	305	76	826	829	584	337	673*	368	568	-	457	512	676	526		
400	337	76	902	905	641	387	724*	372	610	-	457	537	866	603		
450	387	102	978	981	711	438	775*	453	923	-	457	629	1089	871		
500	438	102	1054	1060	775	489	851*	489	742	-	610	665	1451	1202		
550	489	127	1143	1153	838	540	902*	562	820	-	610	762	1928	1497		
600	540	127	1232	1241	914	591	978*	600	914	-	610	801	2291	1950		
650	591	127	1308	1321	972	635	1067*	636	985	-	610	837	2835	2313		
700	635	127	1397	1410	1035	686	1130*	673	1060	-	610	872	3515	2767		
750	686	127	1524	1537	1092	737	1194*	708	1139	-	762	907	4309	3447		
800	737	127	1651	1667	1149	832	1245*	750	1217	-	914	949	5216	4241		
900	832	191	1880	1895	1270	876	1384*	894	1362	-	762	1151	7257	5897		

Length (A) of a weld x flanged end valve is one half the sum of length (A) of a weld end and a flange end of the same size and rating.

* Short pattern.

¹⁾ Dimensions of 22 in. (550 mm) flanges are per MSS-SP-44 and 26 in. (650 mm) through 42 in. (1050 mm) flanges are per ASME B16.47 Series A.

Note: Venturi opening or other reduced bore valves are available upon request.

FULLY WELDED BALL VALVES

FULL BORE ASME/ANSI CLASS 600 (PN 100)

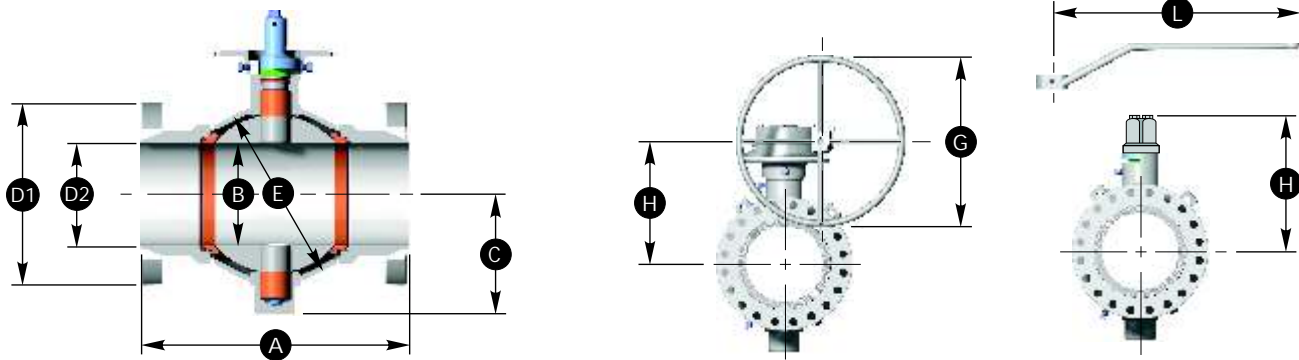

DIMENSIONS

SIZE in.		Ball Bore B	Stem Size	Flanged End		Dia. D1 ¹⁾	Dia. D2	Weld End Length A	C.L. to Bottom C	Body Sphere E	Lever Length L	Diameter Handwheel for Gear G	C.L. to Handwheel C.L. H	Approximate Valve Weight lb.	
Nom Dia.	RF Length A			RTJ Length A	Flange									Weld	
2	2.06	1.0	11.5	11.625	6.50	2.06	11.0*	3.94	5.00	24	-	6.34	60	45	
3	3.13	1.0	14.0	14.125	8.25	3.13	12.5*	5.12	6.75	24	-	7.44	85	75	
4	4.06	1.5	17.0	17.125	10.75	4.06	14.0*	5.94	8.50	36	-	8.43	165	100	
6	6.00	1.5	22.0	22.125	14.00	6.00	18.0*	7.91	11.25	36	-	10.43	360	225	
8	8.00	2.0	26.0	26.125	16.50	8.00	21.5*	10.00	15.50	-	24	12.55	650	450	
10	10.00	2.0	31.0	31.125	20.00	10.00	23.5*	12.12	18.50	-	30	14.54	1000	650	
12	12.00	3.0	33.0	33.125	22.00	12.00	26.5*	14.50	22.36	-	18	20.14	1510	1100	
14	13.25	3.0	35.0	35.125	23.75	13.25	28.5*	14.64	24.00	-	24	21.16	1910	1230	
16	15.25	4.0	39.0	39.125	27.00	15.25	30.5*	17.84	26.32	-	18	24.78	2400	1770	
18	17.25	4.0	43.0	43.125	29.25	17.25	33.5*	19.25	29.20	-	24	26.19	2955	2200	
20	19.25	5.0	47.0	47.250	32.00	19.25	35.5*	22.11	32.27	-	24	30.00	4100	3000	
22	21.25	5.0	51.0	51.375	34.25	21.25	38.5*	23.63	36.00	-	24	31.53	5400	3950	
24	23.25	5.0	55.0	55.375	37.00	23.25	42.0*	25.05	38.76	-	30	32.95	6550	4750	
26	25.00	5.0	57.0	57.500	40.00	25.00	44.5*	26.49	41.75	-	36	34.34	7800	5600	
28	27.00	7.5	61.0	61.500	42.25	27.00	47.0*	30.87	44.86	-	30	40.99	9500	6700	
30	29.00	7.5	65.0	65.500	44.50	29.00	49.0*	32.53	47.90	-	30	42.65	12000	9120	
34	32.75	7.5	76.0	76.625	49.00	32.75	54.5*	35.19	53.64	-	42	45.31	16025	12300	
36	34.50	7.5	82.0	82.625	51.75	34.50	56.5*	36.80	56.83	-	42	46.92	19100	15500	
40	38.50	9.0	80.0	-	52.00	38.50	65.0*	42.02	65.00	-	42	55.425	26770	23000	
42	41.25	9.0	83.0	-	55.25	41.25	66.5*	43.66	68.60	-	42	57.06	30500	25500	
48	46.50	11.0	94.0	-	62.75	46.50	76.0*	51.18	77.33	-	-	-	-	-	-
SIZE mm													kg		
50	52	25	292	295	165	52	279*	100	127	610	-	161	27	20	
80	80	25	356	359	210	80	318*	130	171	610	-	189	39	34	
100	103	38	432	435	273	103	356*	151	216	914	-	214	75	45	
150	152	38	559	562	356	152	457*	201	286	914	-	265	163	102	
200	203	51	660	664	419	203	546*	254	394	-	610	319	295	204	
250	254	51	787	791	508	254	597*	308	470	-	762	369	454	295	
300	305	76	838	841	559	304	673*	368	568	-	457	512	685	499	
350	337	76	889	892	603	337	724*	372	610	-	610	537	866	558	
400	387	102	991	994	686	387	775*	453	669	-	457	629	1089	803	
450	438	102	1092	1095	743	438	851*	489	742	-	610	665	1340	998	
500	489	127	1194	1200	813	489	902*	562	820	-	610	762	1860	1361	
550	540	127	1295	1305	870	540	978*	600	914	-	610	801	2449	1792	
600	591	127	1397	1407	940	591	1067*	636	985	-	762	837	2971	2155	
650	635	127	1448	1461	1016	635	1130*	673	1060	-	914	872	3538	2540	
700	686	191	1549	1562	1073	686	1194*	784	1139	-	762	1041	4309	3039	
750	737	191	1651	1664	1130	737	1245*	826	1217	-	762	1083	5443	4137	
850	832	191	1930	1946	1245	832	1384*	894	1362	-	1067	1151	7269	5579	
900	876	191	2083	2099	1314	876	1435*	935	1443	-	1067	1192	8664	7031	
1000	978	229	2032	-	1321	978	1651*	1067	1651	-	1067	1408	12143	10433	
1050	1048	229	2108	-	1403	1048	1689*	1109	1742	-	1067	1449	13835	11567	
1200	1181	279	2388	-	1594	1181	1930*	1300	1964	-	-	-	-	-	-

Length (A) of a weld x flanged end valve is one half the sum of length (A) of a weld end and a flange end of the same size and rating.

* Short pattern.

¹⁾ Dimensions of 22 in. (550 mm) flanges are per MSS-SP-44 and 26 in. (650 mm) through 42 in. (1050 mm) flanges are per ASME B16.47 Series A.

FULLY WELDED BALL VALVES REDUCED BORE ASME/ANSI CLASS 600 (PN 100)

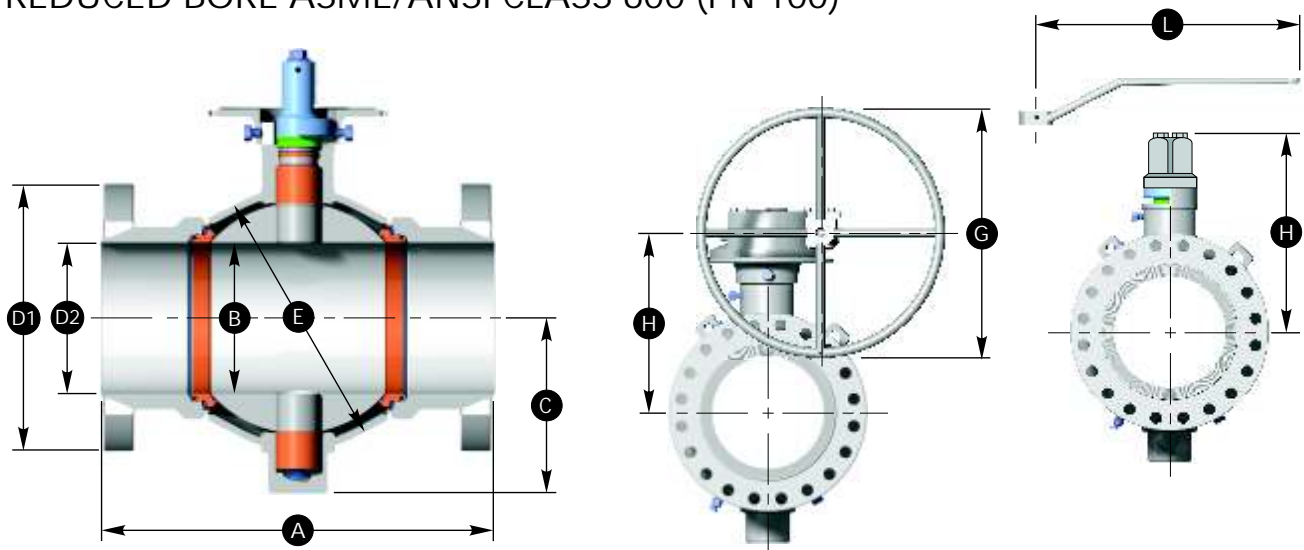

DIMENSIONS

SIZE in.			Flanged End				Weld End Length A	C.L. to Bottom C	Body Sphere E	Lever Length L	Diameter Handwheel for Gear G	C.L. to Handwheel C.L. H	Approximate Valve Weight lb.	
Nom Dia.	Ball Bore B	Stem Size	RF Length A	RTJ Length A	Dia. D1 ¹⁾	Dia. D2							Flange	Weld
3	2.06	1.0	14	14.125	8.25	3.13	11.0*	3.94	5.00	24	-	6.34	80	50
4	3.13	1.0	17	17.125	10.75	4.06	12.5*	5.12	6.75	24	-	7.44	150	87
6	4.06	1.5	22	22.125	14.00	6.00	14.0*	5.94	8.50	36	-	8.43	250	150
8	6.00	1.5	26	26.125	16.50	8.00	18.0*	7.91	11.25	36	-	10.43	470	290
10	8.00	2.0	31	31.125	20.00	10.00	21.5*	10.00	15.50	-	24	12.55	850	525
12	10.00	2.0	33	33.125	22.00	12.00	23.5*	12.12	18.50	-	30	14.54	1150	840
14	12.00	3.0	35	35.125	23.75	13.25	26.5*	14.50	22.36	-	18	20.14	1640	1160
16	13.25	3.0	39	39.125	27.00	15.25	28.5*	14.64	24.00	-	24	21.16	2225	1330
18	15.25	4.0	43	43.125	29.25	17.25	30.5*	17.84	26.32	-	18	24.78	2600	1920
20	17.25	4.0	47	47.250	32.00	19.25	33.5*	19.25	29.20	-	24	26.19	3500	2650
22	19.25	5.0	51	51.375	34.25	21.25	35.5*	22.11	32.27	-	24	30.00	4450	3300
24	21.25	5.0	55	55.375	37.00	23.25	38.5*	23.63	36.00	-	24	31.53	5750	4300
26	23.25	5.0	57	57.500	40.00	25.00	42.0*	25.05	38.76	-	30	32.95	7000	5100
28	25.00	5.0	61	61.500	42.25	27.00	44.5*	26.49	41.75	-	36	34.34	8600	6300
30	27.00	7.5	65	65.500	44.50	29.00	47.0*	30.87	44.86	-	30	40.99	10100	7800
32	29.00	7.5	70	70.625	47.00	32.75	49.0*	32.53	47.90	-	30	42.65	12800	9350
36	32.75	7.5	82	82.625	51.75	34.50	54.5*	35.19	53.64	-	42	45.31	17600	13000
42	34.50	7.5	83	-	55.25	41.25	56.5*	36.80	56.83	-	42	46.92	-	-
SIZE mm												kg		
80	52	25	356	359	210	80	279*	100	127	610	-	161	36	23
100	80	25	432	435	273	103	318*	130	171	610	-	189	68	39
150	103	38	559	562	356	152	356*	151	216	914	-	214	113	68
200	152	38	660	664	419	203	457*	201	286	914	-	265	213	132
250	203	51	787	791	508	254	546*	254	394	-	610	319	386	238
300	254	51	838	841	559	305	597*	308	470	-	762	369	522	381
350	305	76	889	892	603	337	673*	368	568	-	457	512	744	526
400	337	76	991	994	686	387	724*	372	610	-	610	537	1009	603
450	387	102	1092	1095	743	438	775*	453	669	-	457	629	1179	871
500	438	102	1194	1200	813	489	851*	489	742	-	610	665	1588	1202
550	489	127	1295	1305	870	540	902*	562	820	-	610	762	2018	1497
600	540	127	1397	1407	940	591	978*	600	914	-	610	801	2608	1950
650	591	127	1448	1461	1016	635	1067*	636	985	-	762	837	3175	2313
700	635	127	1549	1562	1073	686	1130*	673	1060	-	914	872	3901	2858
750	686	191	1651	1664	1130	737	1194*	784	1139	-	762	1041	4581	3538
800	737	191	1778	1794	1194	832	1245*	826	1217	-	762	1083	5806	4241
900	832	191	2083	2099	1314	876	1384*	894	1362	-	1067	1151	7983	5897

Length (A) of a weld x flanged end valve is one half the sum of length (A) of a weld end and a flange end of the same size and rating.

* Short pattern.

¹⁾ Dimensions of 22 in. (550 mm) flanges are per MSS-SP-44 and 26 in. (650 mm) through 42 in. (1050 mm) flanges are per ASME B16.47 Series A.

Note: Venturi opening or other reduced bore valves are available upon request.

FULLY WELDED BALL VALVES

FULL BORE ASME/ANSI CLASS 900 (PN 150)

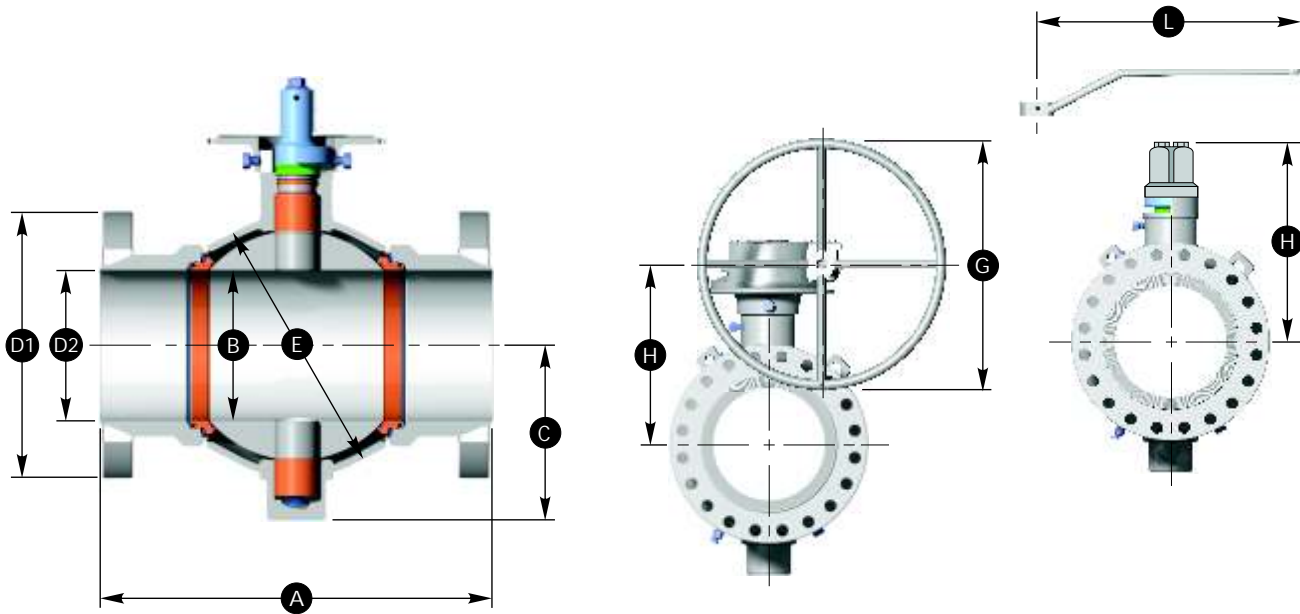

DIMENSIONS

SIZE in.	Ball Bore B	Stem Size	RF Length A	Flanged End RTJ Length A	Dia. D1 ¹⁾	Dia. D2	Weld End Length A	C.L. to Bottom C	Body Sphere E	Lever Length L	Diameter Handwheel for Gear G	C.L. to Handwheel C.L. H	Approximate Valve Weight lb.		
Nom Dia.													Flange	Weld	
2	2.06	Use 1500 Class Valves (PN 250)													
3	3.13	1.5	15.0	15.125	9.50	3.13	13.5*	4.88	7.00	36	-	7.44	140	120	
4	4.06	2.0	18.0	18.125	11.50	4.06	15.0*	6.77	9.25	-	18	9.76	250	190	
6	6.00	2.0	24.0	24.125	15.00	6.00	20.0*	8.39	12.50	-	24	10.86	525	410	
8	8.00	2.0	29.0	29.125	18.50	8.00	23.5*	10.00	15.50	-	30	12.55	1210	590	
10	10.00	3.0	33.0	33.125	21.50	10.00	25.5*	12.88	18.50	-	18	18.49	1325	1010	
12	12.00	3.0	38.0	38.125	24.00	12.00	29.5*	14.50	22.36	-	24	20.14	2250	1350	
14	12.75	5.0	40.5	40.875	25.25	12.75	31.5*	17.40	24.50	-	24	25.30	3250	2155	
16	14.75	5.0	44.5	44.875	27.75	14.75	33.5*	19.02	27.25	-	24	26.92	4000	2450	
18	16.75	5.0	48.0	48.500	31.00	16.75	36.5*	20.62	30.07	-	24	28.51	5300	3950	
20	18.625	7.5	52.0	52.500	33.75	18.625	38.5*	24.22	33.88	-	24	35.23	7100	5250	
24	22.50	7.5	61.0	61.750	41.00	22.50	45.0*	28.07	39.95	-	30	38.18	10500	6450	
30	29.00	7.5	75.0	75.875	48.50	29.00	52.0*	32.53	49.88	-	42	42.65	17500	11500	
36	34.50	9.0	90.0	91.125	57.50	34.50	59.5*	38.64	58.25	-	-	52.03	25600	17500	
SIZE mm													kg		
50	52	Use 1500 Class Valves (PN 250)													
30	80	38	381	384	241	80	343*	124	178	914	-	189	64	54	
100	103	51	457	460	292	103	381*	172	235	-	457	248	113	86	
150	152	51	610	613	381	152	508*	213	318	-	610	276	238	186	
200	203	51	737	740	410	203	597*	254	394	-	762	319	549	268	
250	254	76	838	841	546	254	648*	327	470	-	457	470	601	458	
300	305	76	965	968	610	305	749*	368	568	-	610	512	1021	612	
350	324	127	1029	1038	641	324	800*	442	622	-	610	643	1474	977	
400	375	127	1130	1140	705	375	851*	483	692	-	610	684	1814	1111	
450	425	127	1219	1232	787	425	927*	524	764	-	610	724	2404	1792	
500	473	191	1321	1334	857	473	978*	615	861	-	610	895	3221	2381	
600	572	191	1549	1568	1041	572	1143*	713	1015	-	762	970	4763	2926	
750	737	191	1905	1927	1232	737	1321*	826	1267	-	1067	1083	7938	5216	

Length (A) of a weld x flanged end valve is one half the sum of length (A) of a weld end and a flange end of the same size and rating.

* Short pattern.

¹⁾ Dimensions of 22 in. (550 mm) flanges are per MSS-SP-44 and 26 in. (650 mm) through 42 in. (1050 mm) flanges are per ASME B16.47 Series A.

FULLY WELDED BALL VALVES REDUCED BORE ASME/ANSI CLASS 900 (PN 150)

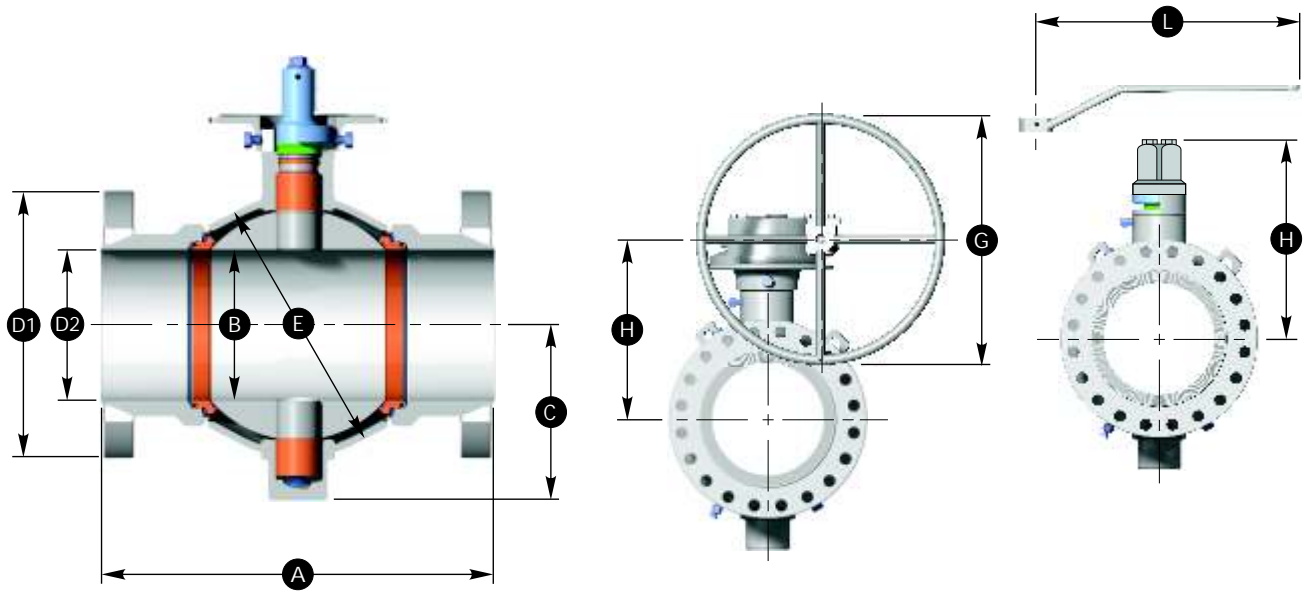

DIMENSIONS

SIZE in.	Ball Bore B	Stem Size	Flanged End		Weld End	C.L. to Bottom C	Body Sphere E	Lever Length L	Diameter Handwheel for Gear G	C.L. to Handwheel C.L. H	Approximate Valve Weight lb.			
Nom Dia.	B		RF Length A	RTJ Length A	Dia. D1 ¹⁾	Dia. D2	A				Flange	Weld		
3	2.06	1.0	15.0	15.125	9.50	3.13	11.0*	3.94	5.00	24	-	6.34	120	70
4	3.13	1.5	18.0	18.125	11.50	4.06	13.5*	4.88	7.00	36	-	7.44	190	150
6	4.06	2.0	24.0	24.125	15.00	6.00	15.0*	6.77	9.25	-	18	9.76	400	260
8	6.00	2.0	29.0	29.125	18.50	8.00	20.0*	8.39	12.50	-	24	10.86	850	650
10	8.00	2.0	33.0	33.125	21.50	10.00	23.5*	10.00	15.50	-	30	12.55	1290	725
12	10.00	3.0	38.0	38.125	24.00	12.00	25.5*	12.88	18.50	-	18	18.49	1700	1110
14	12.00	3.0	40.5	40.875	25.25	12.75	29.5*	14.50	22.36	-	24	20.14	2750	1680
16	12.75	5.0	44.5	44.875	27.75	14.75	31.5*	17.40	24.50	-	24	25.30	3650	2300
SIZE mm											kg			
80	52	25	381	384	241	80	279*	100	127	610	-	161	54	32
100	80	38	457	460	292	103	343*	124	178	914	-	189	86	68
150	103	51	610	613	381	152	381*	172	235	-	457	248	181	118
200	152	51	737	740	470	203	508*	213	318	-	610	276	386	295
250	203	51	838	841	546	254	597*	254	394	-	762	319	585	329
300	254	76	965	968	610	305	648*	327	470	-	457	470	771	503
350	305	76	1029	1038	641	324	749*	368	568	-	610	512	1247	762

Length (A) of a weld x flanged end valve is one half the sum of length (A) of a weld end and a flange end of the same size and rating.

* Short pattern.

¹⁾ Dimensions of 22 in. (550 mm) flanges are per MSS-SP-44 and 26 in. (650 mm) through 42 in. (1050 mm) flanges are per ASME B16.47 Series A.

Note: Venturi opening or other reduced bore valves are available upon request.

FULLY WELDED BALL VALVES FULL BORE ASME/ANSI CLASS 1500 (PN 250)

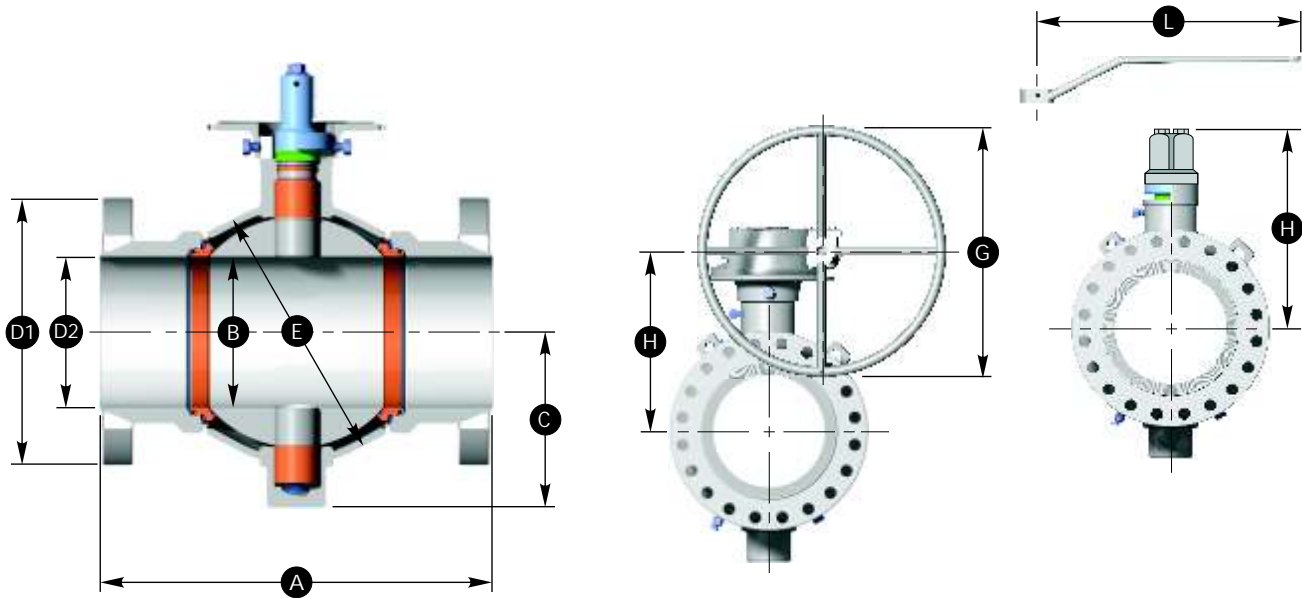

DIMENSIONS

SIZE in.	Nom Dia.	Ball Bore B	Stem Size	Flanged End		Weld End Length A	C.L. to Bottom C	Body Sphere E	Lever Length L	Diameter Handwheel for Gear G	C.L. to Handwheel C.L. H	Approximate Valve Weight lb.		
				RF Length A	RTJ Length A							Flange	Weld	
2	2.06	1.0	14.50	14.625	8.50	2.06	11.0*	3.94	5.00	24	-	6.34	100	45
3	3.13	1.5	18.50	18.625	10.50	3.13	13.5*	4.88	7.00	36	-	7.44	180	120
4	4.06	2.0	21.50	21.625	12.25	4.06	15.0*	6.77	9.25	-	18	9.76	300	190
6	6.00	2.0	27.75	28.000	15.50	6.00	20.0*	8.39	12.50	-	30	10.86	715	410
8	8.00	3.0	32.75	33.125	19.00	8.00	23.5*	10.95	16.38	-	18	16.89	1550	1075
10	10.00	4.0	39.00	39.375	23.00	10.00	25.5*	15.15	19.50	-	18	19.96	2000	1575
12	12.00	4.0	44.50	45.125	26.50	12.00	29.5*	17.31	23.38	-	24	21.80	3250	1825
14	12.75	5.0	49.50	50.250	29.50	12.75	31.5*	17.40	26.00	-	24	25.30	4200	2550
16	14.75	5.0	54.50	55.375	32.50	14.75	33.5*	19.02	29.25	-	30	26.92	5400	2950
18	16.75	7.5	60.50	61.375	36.00	16.75	36.5*	22.69	31.57	-	30	33.71	6350	5125
20	18.625	7.5	65.50	66.375	38.75	18.625	38.5*	24.22	34.72	-	30	35.23	9260	6025
24	22.50	7.5	76.50	77.625	46.00	22.50	45.0*	28.07	42.16	-	48	38.18	16250	9400
SIZE mm												kg		
50	52	25	368	371	216	52	279*	100	127	610	-	161	45	20
80	80	38	470	473	267	80	343*	124	178	914	-	189	82	54
100	103	51	546	549	311	103	381*	172	235	-	457	248	136	86
150	152	51	705	711	394	152	508*	213	318	-	762	276	324	186
200	203	76	832	841	483	203	597*	278	416	-	457	429	703	488
250	254	102	991	1000	584	254	648*	385	495	-	457	507	907	714
300	305	102	1130	1146	673	305	749*	440	394	-	610	554	1474	828
350	324	127	1257	1276	749	324	800*	442	660	-	610	643	1905	1157
400	375	127	1384	1407	826	375	851*	483	743	-	762	684	2449	1338
450	425	191	1537	1559	914	425	927*	576	802	-	762	856	2880	2325
500	473	191	1664	1686	984	473	978*	615	882	-	762	895	4200	2733
600	572	191	1943	1972	1168	572	1143*	713	1071	-	1219	970	7371	4264

Length (A) of a weld x flanged end valve is one half the sum of length (A) of a weld end and a flange end of the same size and rating.

* Short pattern.

FULLY WELDED BALL VALVES REDUCED BORE ASME/ANSI CLASS 1500 (PN 250)

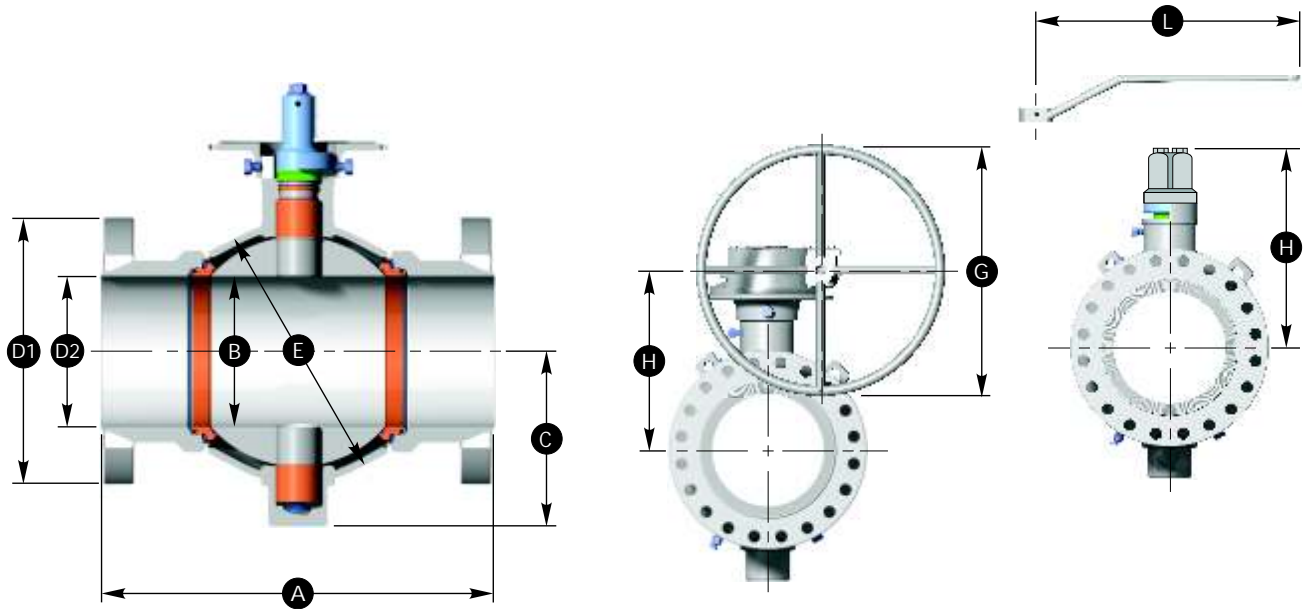

DIMENSIONS

SIZE in.	Ball Bore B	Stem Size	Flanged End				Weld End Length A	C.L. to Bottom C	Body Sphere E	Lever Length L	Diameter Handwheel for Gear G	C.L. to Handwheel C.L. H	Approximate Valve Weight lb.		
Nom Dia.			RF Length A	RTJ Length A	Dia. D1	Dia. D2							Flange	Weld	
3	2.06	1.0	18.50	18.625	10.50	3.13	11.0*	3.94	5.00	24	-	6.34	150	70	
4	3.13	1.5	21.50	21.625	12.25	4.06	13.5*	4.88	7.00	36	-	7.44	240	150	
6	4.06	2.0	27.75	28.000	15.50	6.00	15.0*	6.77	9.25	-	18	9.76	550	260	
8	6.00	2.0	32.75	33.125	19.00	8.00	20.0*	8.39	12.50	-	30	10.86	1025	650	
10	8.00	3.0	39.00	39.375	23.00	10.00	23.5*	10.95	16.38	-	18	16.89	1725	1200	
12	10.00	4.0	44.50	45.125	26.50	12.00	25.5*	15.15	19.50	-	18	19.96	2810	1650	
14	12.00	4.0	49.50	50.250	29.50	12.75	29.5*	17.31	23.38	-	24	21.80	3750	2100	
16	12.75	5.0	54.50	55.375	32.50	14.75	31.5*	17.40	26.00	-	24	25.30	5150	2725	
SIZE mm															kg
80	52	25	470	473	267	80	279*	100	127	610	-	161	68	32	
100	90	38	546	549	311	103	343*	124	178	914	-	189	109	68	
150	103	51	705	711	394	152	381*	172	235	-	457	248	249	118	
200	152	51	832	841	483	203	508*	213	318	-	762	276	465	295	
250	203	76	991	1000	584	254	597*	278	416	-	457	429	782	544	
300	254	102	1130	1146	673	305	648*	385	495	-	457	507	1275	748	
350	305	102	1257	1276	749	324	749*	440	594	-	610	554	1701	953	
400	324	127	1384	1407	826	375	800*	442	660	-	610	643	2336	1236	

Length (A) of a weld x flanged end valve is one half the sum of length (A) of a weld end and a flange end of the same size and rating.

* Short pattern.

Note: Venturi opening or other reduced bore valves are available upon request.

FULLY WELDED BALL VALVES

FULL AND REDUCED BORE ASME/ANSI CLASS 2500 (PN 420)

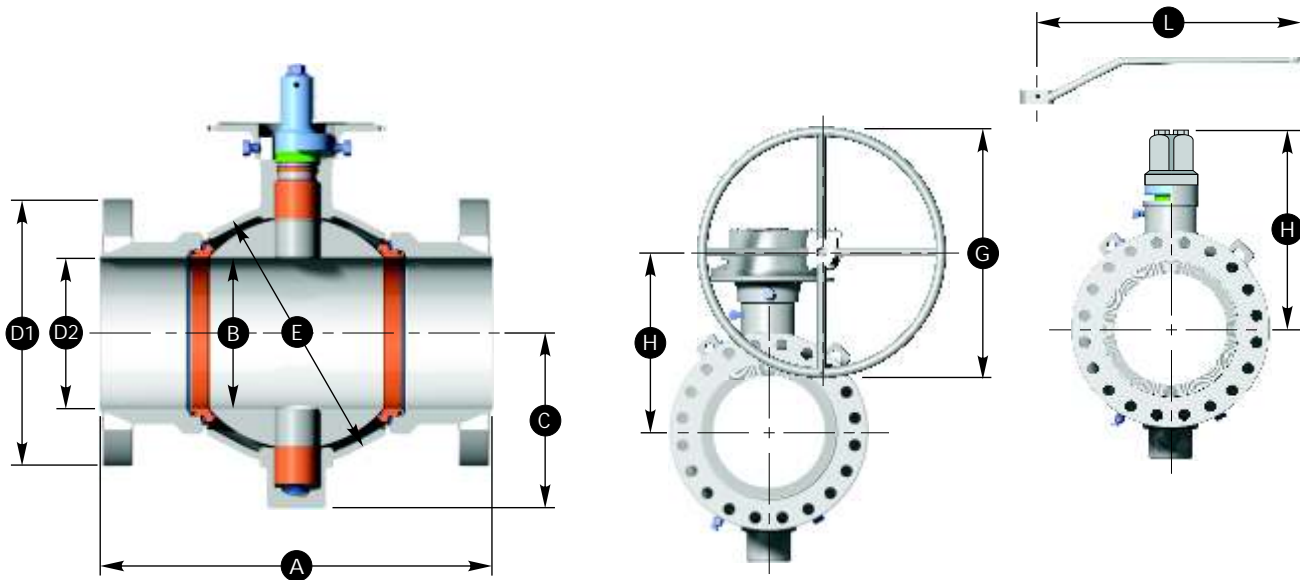

DIMENSIONS

SIZE in.	Ball Bore B	Stem Size	RF Length A	Flanged End RTJ Length A	Dia. D1	Dia. D2	C.L. Weld End Length A	to Bottom C	Body Sphere E	Diameter Lever Length L	C.L. to Handwheel for Gear G	Approximate Handwheel C.L. H	Valve Weight lb. Flange	Weld
FULL OPENING														
2	2.06	1.0	17.75	17.875	9.25	2.06	15*	4.53	5.43	24	-	7.25	114	94
3	3.13	1.5	22.75	23.000	12.00	3.13	18*	5.67	7.50	36	-	8.94	236	187
4	4.06	2.0	26.50	26.875	14.00	4.06	20*	7.24	9.75	-	24	11.70	471	382
6	6.00	3.0	36.00	36.500	19.00	6.00	24*	9.76	13.50	-	24	13.13	943	737
8	7.125	4.0	40.50	40.875	21.75	7.125	28*	12.84	18.11	-	24	17.88	2094	1676
10	8.875	4.0	50.00	50.875	26.50	8.875	33*	14.84	20.87	-	24	20.00	2922	2166
12	10.50	5.0	56.00	56.875	30.00	10.50	36*	16.65	24.50	-	30	24.75	4506	3258
REDUCED OPENING														
3	2.06	1.0	22.75	23.000	12.00	3.13	15*	4.53	5.43	21	-	7.25	156	129
4	3.13	1.5	26.50	26.875	14.00	4.06	18*	5.67	7.50	36	-	8.94	286	247
6	4.06	2.0	36.00	36.500	19.00	6.00	20*	7.24	9.75	-	24	11.70	638	513
8	6.00	3.0	40.50	40.875	21.75	7.125	24*	9.76	13.50	-	24	13.13	1297	1017
10	7.13	4.0	50.00	50.875	26.50	8.875	28*	12.84	18.11	-	24	17.88	2518	1916
12	8.875	4.0	56.00	56.875	30.00	10.50	33*	14.875	20.87	-	24	20.00	3566	2657
SIZE mm													kg	
FULL OPENING														
50	52	25	451	454	235	52	381*	115	138	610	-	184	52	43
80	80	38	578	584	305	80	457*	144	191	914	-	227	107	85
100	103	51	673	683	356	103	508*	184	248	-	610	297	214	173
150	152	76	914	927	483	152	610*	248	343	-	610	334	428	334
200	181	102	1029	1038	552.5	181	711*	326	460	-	610	454	950	760
250	225	102	1270	1292	673	225	838*	378	530	-	610	508	1325	983
300	267	127	1422	1445	762	267	914*	423	622	-	762	629	2044	1478
REDUCED OPENING														
80	42	25	578	584	305	80	381*	115	138	610	-	184	71	59
100	80	38	673	683	356	103	457*	144	191	914	-	227	130	98
150	103	51	914	927	483	152	508*	184	248	-	610	297	289	233
200	152	76	1029	1038	553	181	610*	248	343	-	610	334	588	461
250	181	102	1270	1292	673	225	711*	326	460	-	610	454	1142	869
300	225	102	1422	1445	762	267	838*	377	530	-	610	508	1618	1205

Length (A) of a weld x flanged end valve is one half the sum of length (A) of a weld end and a flange end of the same size and rating.

* Short pattern.

Note: Venturi opening or other reduced bore valves are available upon request.

FULLY WELDED BALL VALVES

FULL BORE API FLANGED 2000, 3000 & 5000 psi WP

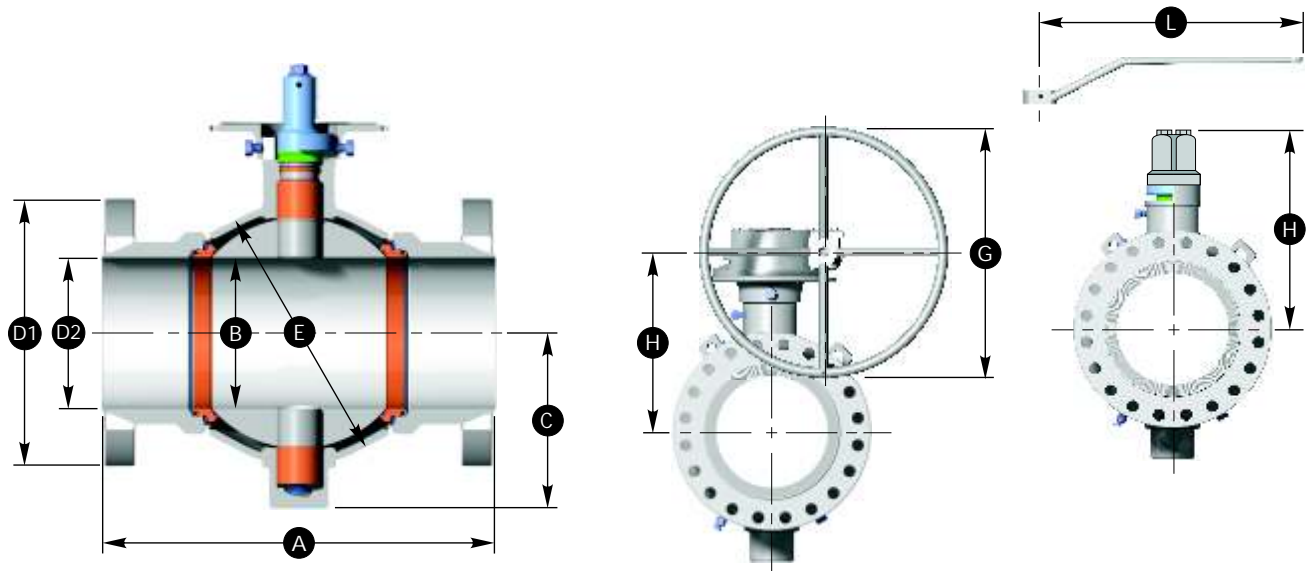

DIMENSIONS

SIZE in.			Flanged End RTJ			C.L. to Bottom C	Body Sphere E	Lever Length L	Diameter Handwheel for Gear G	Data for Valve with Operator Normally Furnished Approx. Weight lb.	
Nom Dia.	Ball Bore B	Stem Size	Length A	Length D1	Dia. D2					H	H
2000 psi W.P. 4000 psi TEST											
2	2.06	1.0	11.625	6.50	2.06	3.94	5.00	36	-	6.34	44
3	3.13	1.0	14.124	8.25	3.13	5.12	6.75	36	-	7.44	85
4	4.06	1.5	17.125	10.75	4.06	5.94	8.50	36	-	8.43	165
7	6.00	2.0	22.125	14.00	6.00	7.91	11.50	-	24	10.29	445
3000 psi W.P. 6000 psi TEST											
2	2.06	1.0	14.625	8.50	2.06	3.94	5.00	36	-	6.34	90
3	3.13	1.5	15.125	9.50	3.13	4.88	7.00	36	-	7.44	130
4	4.06	2.0	18.125	11.50	4.06	6.77	9.25	36	-	9.76	255
7	6.00	2.0	24.125	15.00	6.00	8.39	12.50	-	30	10.92	675
5000 psi W.P. 10000 psi TEST											
2	2.06	2.0	14.625	8.50	2.06	3.94	5.00	36	-	6.34	95
3	3.13	1.5	18.625	10.50	3.13	4.88	7.00	36	-	7.44	189
4	4.06	2.0	21.625	12.25	4.06	6.77	9.25	-	24	9.30	361
7	6.00	3.0	28.000	15.50	6.00	8.39	13.50	-	24	13.13	805
SIZE mm											kg
140.6 kg/cm ² W.P. 281.2 kg/cm ² TEST											
50	52.3	25.4	295	165	52	100	127	914	-	161	20
80	79.5	25.4	359	210	80	130	171	914	-	189	39
100	103.1	38.1	435	274	103	151	216	914	-	214	75
180	152.4	50.8	562	356	152	201	292	-	610	261	202
210.9 kg/cm ² W.P. 421.8 kg/cm ² TEST											
50	52.3	25.4	371	216	52	100	127	914	-	161	41
80	79.5	38.1	384	241	80	124	178	914	-	189	59
100	103.1	50.8	460	292	103	172	235	914	-	248	116
180	152.4	50.8	613	381	152	213	318	-	762	277	306
351.5 kg/cm ² W.P. 703.0 kg/cm ² TEST											
50	52.3	25.4	371	216	52	100	127	914	-	161	43
80	79.5	38.1	473	267	80	124	178	914	-	189	86
100	103.1	50.8	549	311	103	172	235	914	-	236	164
180	152.4	76.2	711	394	152	213	343	-	610	334	365

FULLY WELDED BALL VALVES

REDUCED BORE API FLANGED 2000, 3000 & 5000 psi WP

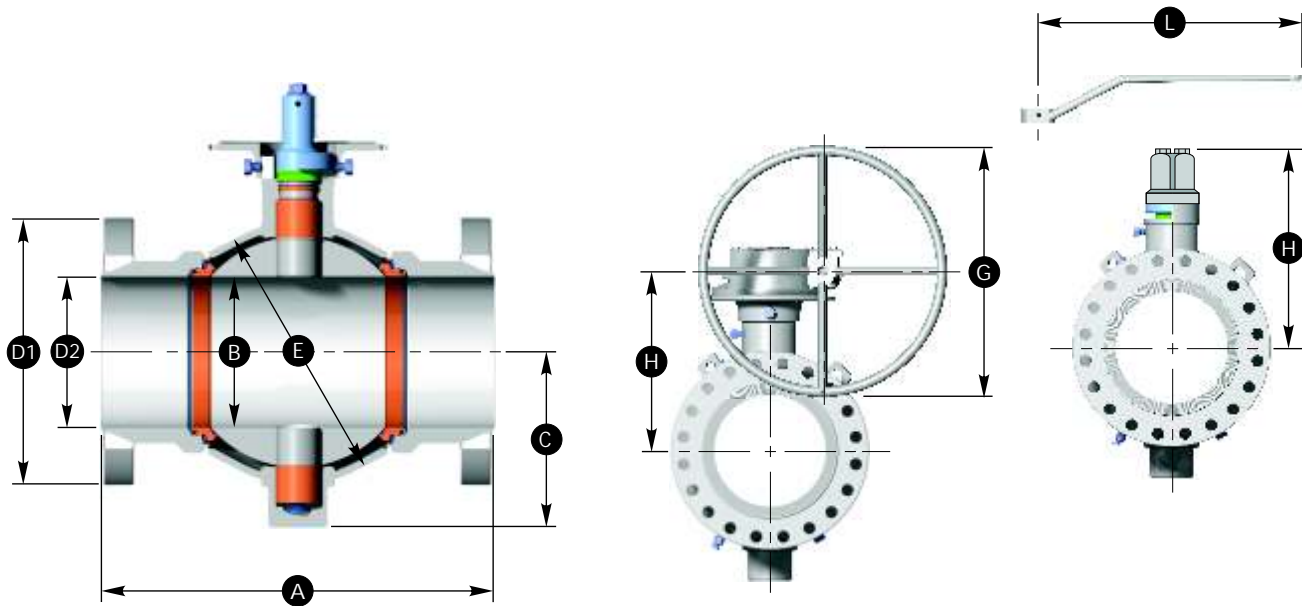

DIMENSIONS

SIZE in.			Flanged End RTJ			C.L. to Bottom C	Body Sphere E	Lever Length L	Diameter Handwheel for Gear G	Data for Valve with Operator Normally Furnished	
Nom Dia.	Ball Bore B	Stem Size	Length A	Dia. D1	Dia. D2					H	Approx. Weight lb. Flange
2000 psi W.P. 4000 psi TEST											
3.13	2.06	1.0	14.125	8.25	3.13	3.94	5.00	36	-	6.34	80
4.06	3.13	1.0	17.125	10.75	4.06	5.12	6.75	36	-	7.44	140
7.06	4.06	1.5	22.125	14.00	6.00	5.94	8.50	36	-	8.43	230
3000 psi W.P. 6000 psi TEST											
3.13	2.06	1.0	15.125	9.50	3.13	3.94	5.00	36	-	6.34	105
4.06	3.13	1.5	18.125	11.50	4.06	4.88	7.00	36	-	7.44	197
7.06	4.06	2.0	24.125	15.00	6.00	6.77	9.25	36	-	9.76	345
5000 psi W.P. 10000 psi TEST											
3.13	2.06	1.0	18.625	10.50	3.13	3.94	5.00	36	-	6.34	130
4.06	3.13	1.5	21.625	12.25	4.06	4.88	7.00	36	-	7.44	230
7.06	4.06	2.0	28.000	15.50	6.00	6.77	9.25	-	24	9.30	490
SIZE mm										kg Flange	
140.6 kg/cm ² W.P. 281.2 kg/cm ² TEST											
79.5	52.3	25.4	359	210	80	100	127	914	-	161	36
103.1	79.5	25.4	435	273	103	130	171	914	-	189	64
179.3	103.1	38.1	562	356	152	151	216	914	-	214	104
210.9 kg/cm ² W.P. 421.8 kg/cm ² TEST											
79.5	52.3	25.4	384	241	80	100	127	914	-	161	48
103.1	79.5	38.1	460	292	103	124	178	914	-	189	89
179.4	103.1	50.8	613	381	152	172	235	914	-	248	156
351.5 kg/cm ² W.P. 703.0 kg/cm ² TEST											
79.5	52.3	25.4	473	267	80	100	127	914	-	161	59
103.1	79.5	38.1	549	311	103	124	178	914	-	189	104
179.3	103.1	50.8	711	394	152	172	235	-	610	236	222

FULLY WELDED BALL VALVES DIMENSIONAL DATA

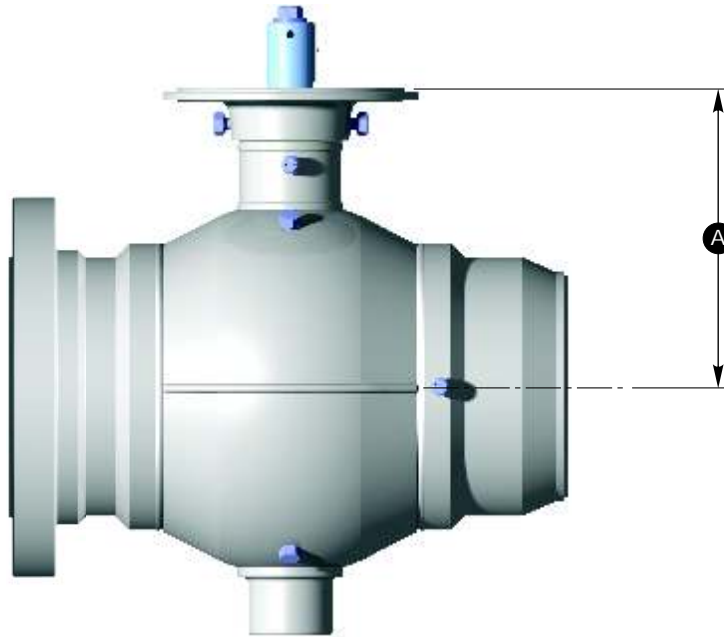

DIMENSIONS CENTERLINE TO MOUNTING FLANGED

Bore Size in. (mm)	Dimension A						
	ASME/ANSI Pressure Class						
	150 (PN 20)	300 (PN 50)	400 (PN 64)	600 (PN 100)	900 (PN 150)	1500 (PN 250)	2500 (PN 420)
2 (50)	4.06 (103)	4.06 (103)	4.06 (103)	4.06 (103)	4.06 (103)	4.06 (103)	4.68 (119)
3 (80)	5.08 (129)	5.08 (129)	5.08 (129)	5.08 (129)	4.76 (121)	4.76 (121)	5.71 (145)
4 (100)	5.79 (147)	5.79 (147)	5.79 (147)	5.79 (147)	6.61 (168)	6.61 (168)	6.89 (175)
6 (150)	7.64 (194)	7.64 (194)	7.64 (194)	7.64 (194)	8.23 (209)	8.23 (209)	12.52 (318)
8 (200)	9.92 (252)	9.92 (252)	9.92 (252)	9.92 (252)	9.92 (252)	13.45 (342)	15.39 (391)
10 (250)	11.91 (303)	11.91 (303)	11.91 (303)	11.91 (303)	15.05 (382)	15.96 (405)	18.07 (459)
12 (300)	16.70 (424)	16.70 (424)	16.70 (424)	16.70 (424)	16.70 (424)	17.80 (452)	19.61 (498)
14 (350)	17.72 (450)	17.72 (450)	17.72 (450)	17.72 (450)	20.55 (522)	20.55 (522)	-
16 (400)	19.08 (485)	19.08 (485)	20.78 (528)	20.78 (528)	22.17 (563)	22.17 (563)	-
18 (450)	22.19 (564)	22.19 (564)	22.19 (564)	22.19 (564)	23.76 (604)	27.71 (704)	-
20 (500)	23.75 (603)	23.75 (603)	25.25 (641)	25.25 (641)	29.23 (742)	29.23 (742)	-
22 (550)	25.22 (641)	25.22 (641)	26.78 (680)	26.78 (680)	-	-	-
24 (600)	26.63 (676)	26.63 (676)	28.20 (716)	28.20 (716)	32.18 (817)	32.18 (817)	-
26 (650)	29.59 (752)	29.59 (752)	29.59 (752)	29.59 (752)	-	-	-
28 (700)	30.97 (787)	30.97 (787)	30.97 (787)	34.99 (889)	-	-	-
30 (750)	32.62 (829)	32.62 (829)	32.62 (829)	36.65 (931)	36.65 (931)	-	-
34 (850)	35.26 (896)	35.26 (896)	39.31 (998)	39.31 (998)	-	-	-
36 (900)	36.85 (936)	40.92 (1039)	40.92 (1039)	40.92 (1039)	44.65 (1134)	-	-
40 (1000)	44.25 (1124)	44.25 (1124)	44.25 (1124)	48.05 (1220)	-	-	-
42 (1050)	45.89 (1166)	45.89 (1166)	45.89 (1166)	49.69 (1262)	-	-	-
48 (1200)	50.04 (1271)	50.04 (1271)	54.02 (1372)	56.50 (1435)	-	-	-

The dimensions on this page, combined with the top works dimensions on the following two pages, provide the information required for determining the overall dimensions of a CAMERON Fully Welded Ball Valve when an actuator is installed.

For additional dimensional information on CAMERON Fully Welded Ball Valves, contact your Cameron's Valves & Measurement group representative.

FULLY WELDED BALL VALVES CAMERON TOP WORKS DIMENSIONS

SQUARE NUT AND ADAPTER FLANGE (BX-1220)

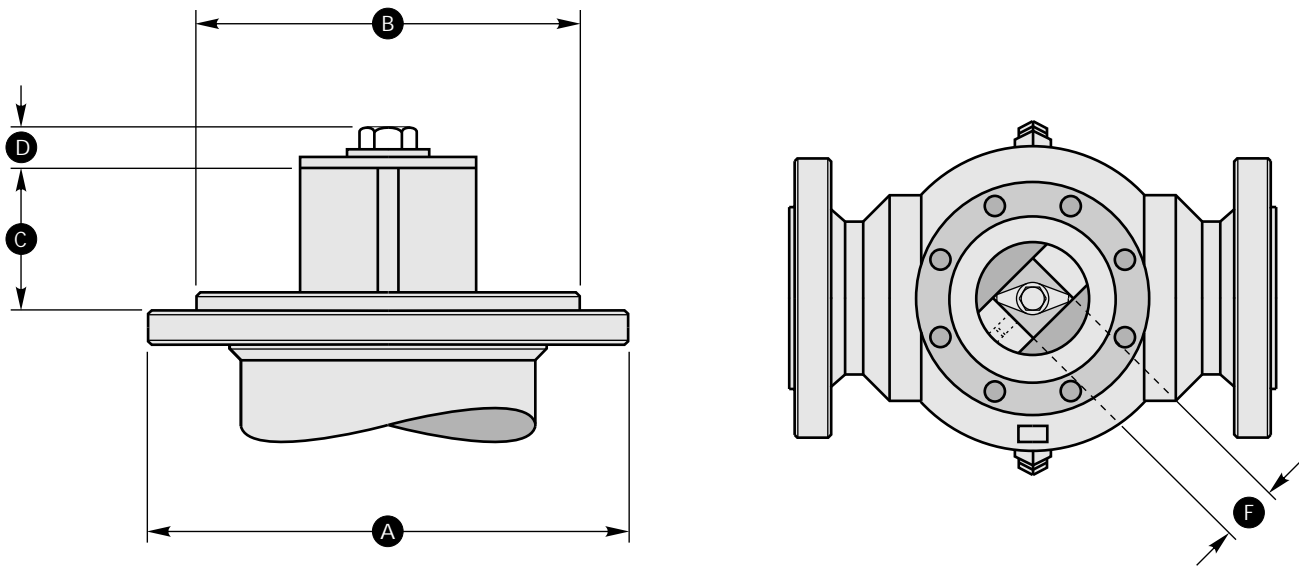

MOUNTING DIMENSIONS

DASH NUMBER	-1	-2	-3
Valve Stem Size in.	1.00	1.50	2.00
A Flange Dia.	6.50	6.50	8.75
B Boss Dia.	4.747	4.747	6.997
C Height of Nut	1.94	2.12	2.62
D Bolt Size	0.44	0.54	0.66
F Width of Nut	1.50	2.00	2.50
H Number of Holes	8	8	16
J Dia. Bolt Circle	5.75	5.75	8.00
Flange Bolt Size	3/8-16 NC-2	3/8-16 NC-2	3/8-16 NC-2
Bolt Torque (ft. lb.)	30	30	30
DASH NUMBER	-1	-2	-3
Valve Stem Size mm	25.40	38.10	50.80
A Flange Dia.	165.10	165.10	222.25
B Boss Dia.	120.57	120.57	177.72
C Height of Nut	49.28	53.85	66.55
D Bolt Size	11.18	13.72	16.76
F Width of Nut	38.10	50.8	63.50
H Number of Holes	8	8	16
J Dia. Bolt Circle	146.05	146.05	203.20
Flange Bolt Size	3/8-16 NC-2	3/8-16 NC-2	3/8-16 NC-2
Bolt Torque (Nm)	40.68	40.68	40.68

Notes: -1 and -2 bolt holes straddle centerline.
-3 bolt holes are on centerline.

FULLY WELDED BALL VALVES CAMERON TOP WORKS DIMENSIONS

KEYED SHAFT AND ADAPTER FLANGE (BX-1221)

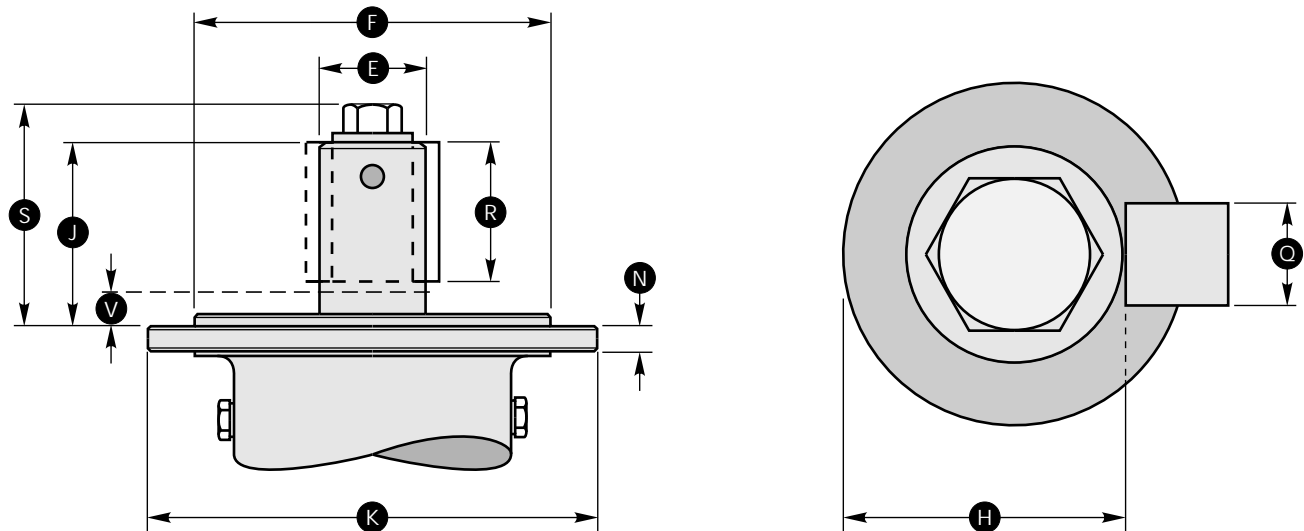

MOUNTING DIMENSIONS

DASH NUMBER	-4	-5	-6	-7	-8	-9	-10	-11
Valve Stem Size in.	3.00	4.00	5.00	7.50	9.00	11.00	13.00	15.00
A Number of Holes	16	16	24	24	24	28	28	32
C Dia. Bolt Circle	10.375	17.25	18.375	24.00	31.00	27.50	27.50	36.00
E Max Shaft Dia.	2.745	3.245	4.495	5.495	6.245	8.995	8.995	-
F Boss Dia.	9.122	16.246	17.121	21.746	28.308	25.496	25.496	33.496
H Key Seat	2.402	2.831	3.786	4.803	5.409	7.887	6.774	-
J Height of Nut	4.75	5.310	6.25	8.50	9.13	13.31	13.31	19.25
K Flange Dia.	11.50	18.25	19.380	25.75	32.75	30.00	30.00	39.00
N Flange Thickness	0.63	0.63	0.63	1.00	1.00	1.25	1.25	1.50
Q Key Width	0.625	0.75	1.25	1.25	1.50	2.00	2.00	2.25
R Key Length	3.75	4.310	5.250	7.50	8.13	12.00	12.00	17.50
S Overall Height	6.120	7.00	8.120	11.00	11.75	16.12	15.84	21.50
V Adapter Flange Thickness (Max.)	1.00	1.00	1.00	1.00	1.00	1.25	1.25	1.50
Flange Bolt Size	1/2-13 NC-2	1/2-13 NC-2	1/2-13 NC-2	7/8-9 NC-2	7/8-9 NC-2	1 1/4-8 NC-2	1 1/4-8 NC-2	1 1/4-8 NC-2
Bolt Torque (ft. lb.)	60	60	63	330	330	1000	1000	1600
DASH NUMBER	-4	-5	-6	-7	-8	-9	-10	-11
Valve Stem Size mm	76.20	101.60	127.00	190.50	228.60	279.40	330.20	381.00
A Number of Holes	16	16	24	24	24	28	28	32
C Dia. Bolt Circle	263.53	438.15	466.73	609.60	787.40	698.50	698.50	914.40
E Max Shaft Dia.	69.73	82.43	114.18	139.58	158.63	228.48	228.48	-
F Boss Dia.	231.69	412.64	434.87	552.34	719.02	647.59	647.59	850.79
H Key Seat	61.01	71.91	96.16	122.00	137.38	200.32	172.05	-
J Height of Nut	120.65	134.88	158.75	215.90	231.91	338.03	338.03	488.95
K Flange Dia.	292.10	463.55	492.26	654.05	831.85	762.00	763.00	990.60
N Flange Thickness	16.00	16.00	16.00	25.40	25.40	31.75	31.75	38.10
Q Key Width	15.88	19.05	31.75	31.75	38.10	50.80	50.80	57.15
R Key Length	95.25	109.48	133.35	190.50	206.51	304.80	304.80	444.50
S Overall Height	155.45	177.80	206.25	279.40	298.45	409.45	402.34	546.10
V Adapter Flange Thickness (Max.)	25.40	25.40	25.40	25.40	25.40	31.75	31.75	38.10
Flange Bolt Size	1/2-13 NC-2	1/2-13 NC-2	1/2-13 NC-2	7/8-9 NC-2	7/8-9 NC-2	1 1/4-8 NC-2	1 1/4-8 NC-2	1 1/4-8 NC-2
Bolt Torque (Nm)	81	81	85	447	447	1356	1356	2169

Notes: -7 through -11 bolt holes straddle centerline.
-4 through -6 holes are on centerline.

FULLY WELDED BALL VALVES - CAMERON TOP WORKS DIMENSIONS

MANUAL GEAR DIMENSIONS FOR CAMERON FULLY WELDED BALL VALVES - ROTORK

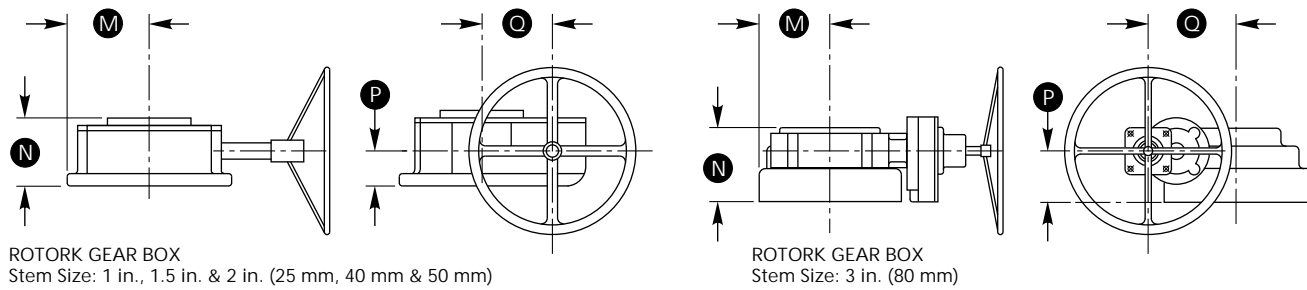

ROTORK GEAR BOX
Stem Size: 1 in., 1.5 in. & 2 in. (25 mm, 40 mm & 50 mm)

ROTORK GEAR BOX
Stem Size: 3 in. (80 mm)

Stem Size in. (mm)	Model	Effective Ratio	Number of Turns Per 90°	M	N	P	Q	Weight lb. (kg)
1.0 (25.4)	AB 880N	13:2	9.5	3.94 (100)	3.58 (91)	1.92 (49)	3.39 (86)	31 (14)
1.5 (38.1)	AB 880N	13:2	9.5	3.94 (100)	3.58 (91)	1.92 (49)	3.39 (86)	31 (14)
2.0 (50.8)	AB 1950N	19:0	13	5.61 (143)	4.68 (119)	2.51 (64)	5.37 (137)	71 (32)
3.0 (76.2)	IW5/IR1	64:6	40	6.40 (163)	8.31 (211)	4.57 (116)	7.85 (199)	187 (85)

MANUAL GEAR DIMENSIONS FOR CAMERON FULLY WELDED BALL VALVES - MASTERGEAR

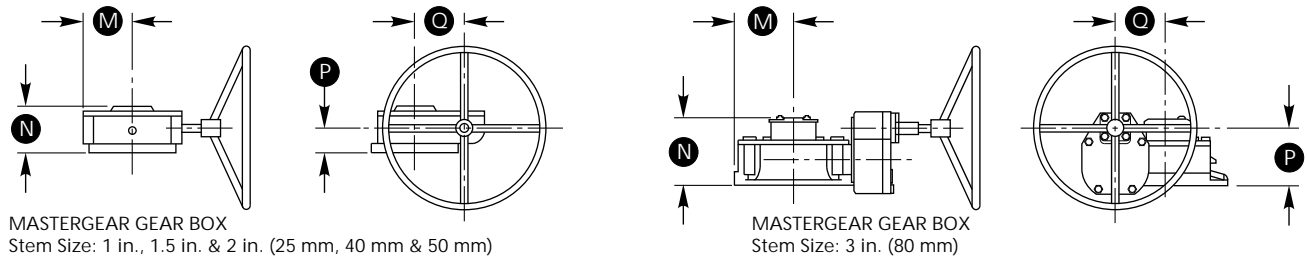

MASTERGEAR GEAR BOX
Stem Size: 1 in., 1.5 in. & 2 in. (25 mm, 40 mm & 50 mm)

MASTERGEAR GEAR BOX
Stem Size: 3 in. (80 mm)

Stem Size in. (mm)	Model	Effective Ratio	Number of Turns Per 90°	M	N	P	Q	Weight lb. (kg)
1.0 (25.4)	MA46	11:1	11.5	3.63 (92)	4.66 (118)	2.50 (64)	3.38 (86)	33 (15)
1.5 (38.1)	MA46	11:1	11.5	3.63 (92)	4.66 (118)	2.50 (64)	3.38 (86)	33 (15)
2.0 (50.8)	MC72	18.3:1	18	4.75 (121)	5.14 (131)	2.63 (67)	5.38 (137)	68 (31)
3.0 (76.2)	MFF36/S5	52:1	45	6.10 (155)	6.76 (172)	5.91 (150)	5.43 (138)	135 (61)

* Normally furnished in above ground application.

MANUAL GEAR DIMENSIONS FOR CAMERON FULLY WELDED BALL VALVES - CAMERON

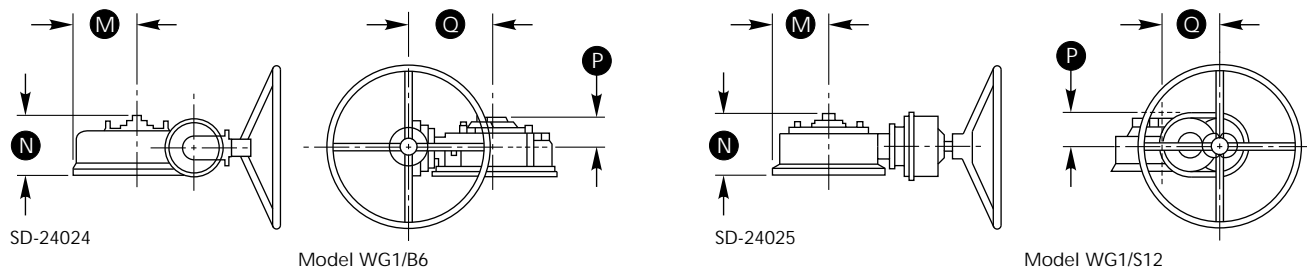

CAMERON GEAR BOX
Stem Size: 3 in. & 4 in. (80 mm & 100 mm)

CAMERON GEAR BOX
Stem Size: 5 in., 7.5 in. & 9 in. (125 mm, 190 mm & 230 mm)

Stem Size in. (mm)	Model	Effective Ratio	Number of Turns Per 90°	M	N	P	Q	Weight lb. (kg)
3.0 (76.2)	WG1/B6	55:1	60	5.75 (146)	7.56 (192)	4.11 (104)	12.64 (321)	127 (58)
4.0 (101.6)	WG1/B6	110:1	112.5	9.13 (232)	8.69 (221)	4.69 (119)	12.64 (321)	211 (96)
5.0 (127.0)	WG1/S12	153:1	190	9.69 (246)	10.25 (260)	5.50 (140)	9.50 (241)	364 (165)
7.5 (190.5)	WG1/S12	297:1	297	12.88 (327)	12.63 (321)	6.63 (168)	14.00 (356)	581 (264)
9.0 (228.6)	WG1/S12	432:1	428	16.37 (416)	14.77 (375)	7.39 (188)	19.50 (495)	793 (360)

TRADEMARK INFORMATION

CAMERON® is a registered trademark which is owned by Cameron.

This document contains references to registered trademarks or product designations, which are not owned by Cameron.

Trademark	Owner
CELCON	Hoechst Celanese Corporation
DELRIN	E.I. DuPont De Nemours & Company
FLUOREL	Minnesota Mining and Manufacturing Company
HASTELLOY	Haynes International, Inc.
HYCAR	Hydrocarbon Chemical and Rubber Company
HYDRIN	Zeon Chemicals USA, Inc.
HYPALON	E.I. DuPont De Nemours & Company
INCONEL	INCO Nickel Sales, Inc.
MONEL	INCO Alloys International, Inc.
NORDEL	E.I. DuPont De Nemours & Company
STELLITE	Stoody Deloro Stellite, Inc.
TEFLON	E.I. DuPont De Nemours & Company
VITON	E.I. DuPont De Nemours & Company

For Benelux:



WEGMAN
Utrecht, The Netherlands
T: +31 (0)30 263 4000
F: +31 (0)30 263 4005
wegman@wegman.nl



VALVES & MEASUREMENT
3250 Briarpark Drive, Suite 300
Houston, Texas 77042
USA Toll Free 800 323 9160

For the most current contact and location information go to: www.c-a-m.com/valvesandmeasurement